

2014 Spare Parts & Tools

ROAD WHEELS

ALUMINIUM WHEELS

RACING ZERO	4
RACING 1	10
RACING 3	14
RACING QUATTRO	18
RACING 5	20
RACING 7	22
RACING SPORT	24

ALU/CARBON WHEELS

RED WIND™ XLR	26
RED WIND™ XLR 80mm	29
RED WIND™ XLR 105mm	32
RED WIND™	34

CARBON WHEELS

RACING LIGHT™ XLR	37
RACING SPEED™ XLR	43
RACING SPEED™ XLR 35	41
RACING SPEED™ XLR 80mm	45
RACING SPEED™	47
RACING SPEED™ 35	49

TT WHEELS

RACING SPEED™ DISC	51
--------------------	----

2014 Spare Parts & Tools

CRANKSETS

RACING TORQ™ RRS	53
RACING TORQ™ R	55

CYCLOCROSS WHEELS

RED WIND™ XLR CX	57
RACING QUATTRO CX	59
RACING 5 CX	61
RACING 7 CX	63

OFF-ROAD WHEELS

XC/MARATHON/ ALL MOUNTAIN

26"	RED CARBON™ XRP	67
	RED METAL ZERO™ XRP	69
	RED METAL™ 1 XL	73
	RED METAL™ 3	79
	RED POWER™ XL	85
	RED POWER™ SL	93
27,5" - 650B	RED METAL™ XRP 650B	97
	RED POWER™ XL 650B	104

2014 Spare Parts & Tools

OFF-ROAD WHEELS

XC/MARATHON/ ALL MOUNTAIN

29" RED METAL™ 29 XRP 108

RED METAL™ 29 XL 115

RED POWER™ 29 XL 117

RED POWER™ 29 SL 121

FREERIDE/ ENDURO/DH

RED ZONE™ XLR 125

RED FIRE™ 129

RED HEAT™ 131

ADAPTERS

133

CUSTOM WHEELS

138

TOOLS

152

SALES & SERVICE

154

RACING ZERO™ CLINCHER

RIMS & SPOKES/CERCHI E RAGGI

RIM

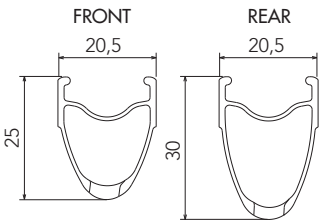
 <p>FRONT 20,5</p> <p>25</p> <p>REAR 20,5</p> <p>30</p>	<p>FRONT RIM REAR RIM LABEL KIT VALVE HOLE DIAMETER TYRE SECTION</p>	<p>ROF-CRB11 (no labels) ROR-CRB11 (no labels) RO-LAB13CB (front+rear) - RO-LAB11CBDK (front+rear DARK) 6,5 mm 622 X 15C See section table and inflation pressures on page 66</p>
---	--	---

SPOKES

<p>COMPLETE FRONT KIT COMPLETE REAR KIT COMPLETE FRONT COMPLETE REAR RIGHT SPOKE COMPLETE REAR LEFT SPOKE NIPPLES SPOKE RING NIPPLE INSERT NIPPLE MAGNET SPOKE SPANNER</p>	<p>ROF-SKB01 (black) - ROF-SKR01 (red) ROR-SKB11 (black) - ROR-SKR11 (red) ROF-SB01 (black) - ROF-SR01 (red) RO-018 (black) - ROR-SR01R (red) ROR-SB01 (black) - ROR-SR01 (red) 10-RO-015 T-02 T-03 T-05 T-07</p>	<p>16 front spokes 14 rear right spokes + 7 rear left spokes spoke + nipple spoke + nipple spoke + nipple 10 pcs anti-rotation magnet-attractor for nipple nipple-guide spoke wrench</p>
--	---	--

ACCESSORIES

<p>Spacer for HG11 FW body</p>	<p>RS-004</p>	<p>5 pcs - to be used only with 9/10s sprockets <i>(please note that every HG11 rear wheel/HG11 FW body package contains the spacer)</i></p>
--------------------------------	---------------	--

RACING ZERO™ CLINCHER

HUBS/MOZZI/MOYEUX

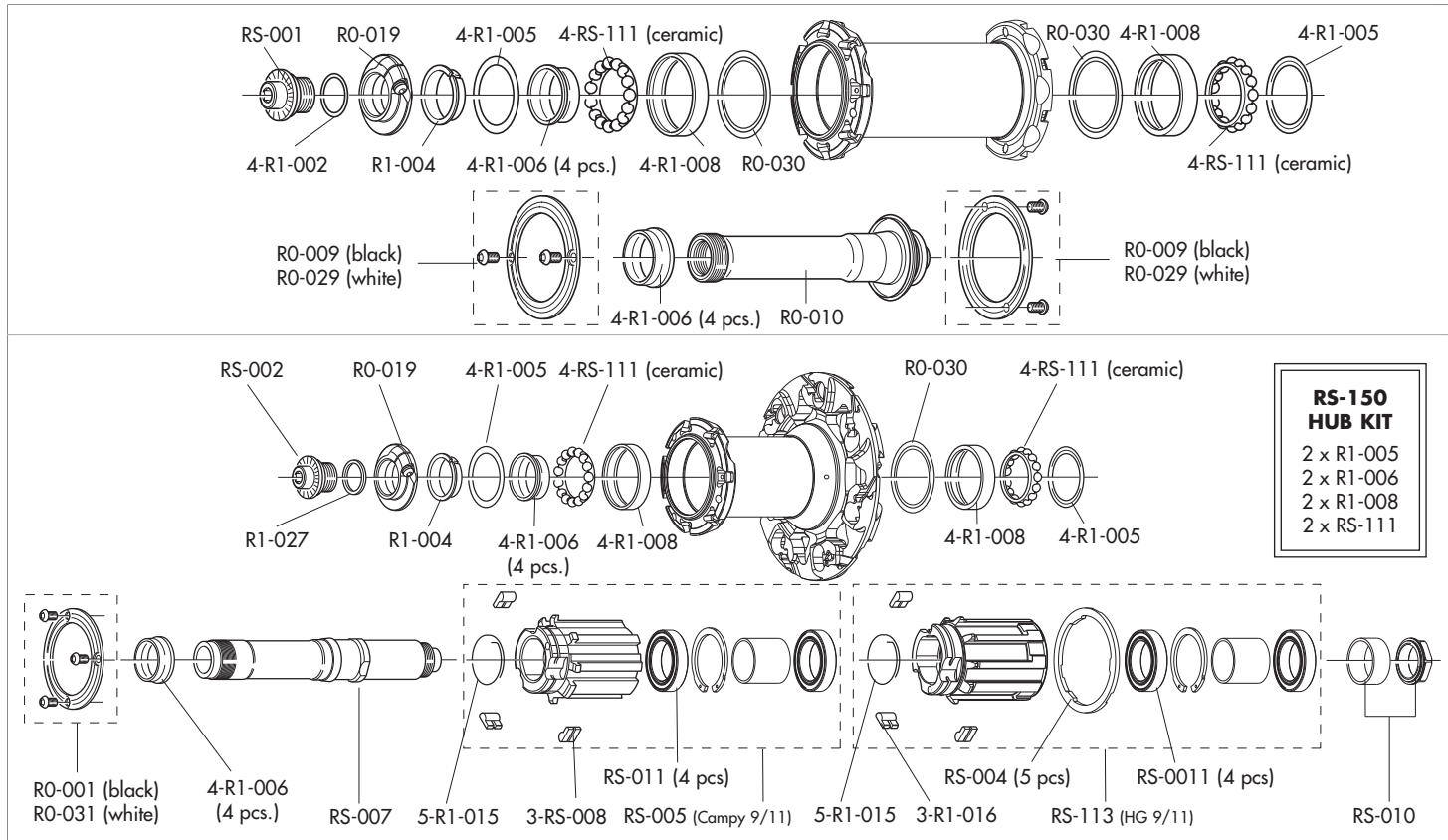

RACING ZERO™ TUBULAR

RIMS & SPOKES/CERCHI E RAGGI

RIM

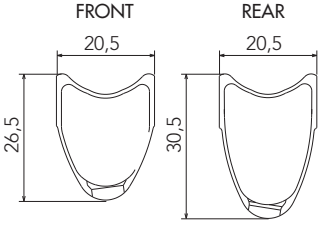
	<p>FRONT RIM REAR RIM LABEL KIT VALVE HOLE DIAMETER TYRE SECTION</p>	<p>R0F-TRB11 (no labels) R0R-TRB11 (no labels) R0-LAB13TRB (front+rear) 6,5 mm 634 mm See recommended tyre manufacturer inflation pressure</p>
--	--	--

SPOKES

<p>COMPLETE FRONT KIT COMPLETE REAR KIT COMPLETE FRONT COMPLETE REAR RIGHT SPOKE COMPLETE REAR LEFT SPOKE NIPPLES SPOKE RING NIPPLE INSERT NIPPLE MAGNET SPOKE SPANNER</p>	<p>R0F-SKB01 R0R-SKB11 R0F-SB01 R0-018 R0R-SB01 10-R0-015 T-02 T-03 T-05 T-07</p>	<p>16 front spokes 14 rear right spokes + 7 rear left spokes spoke + nipple spoke + nipple spoke + nipple 10 pcs anti-rotation magnet-attractor for nipple nipple-guide spoke wrench</p>
--	---	--

ACCESSORIES

<p>Spacer for HG11 FW body</p>	<p>RS-004</p>	<p>5 pcs - to be used only with 9/10s sprockets <i>(please note that every HG11 rear wheel/HG11 FW body package contains the spacer!)</i></p>
--------------------------------	---------------	---

RACING ZERO™ TUBULAR

HUBS/MOZZI/MOYEUX

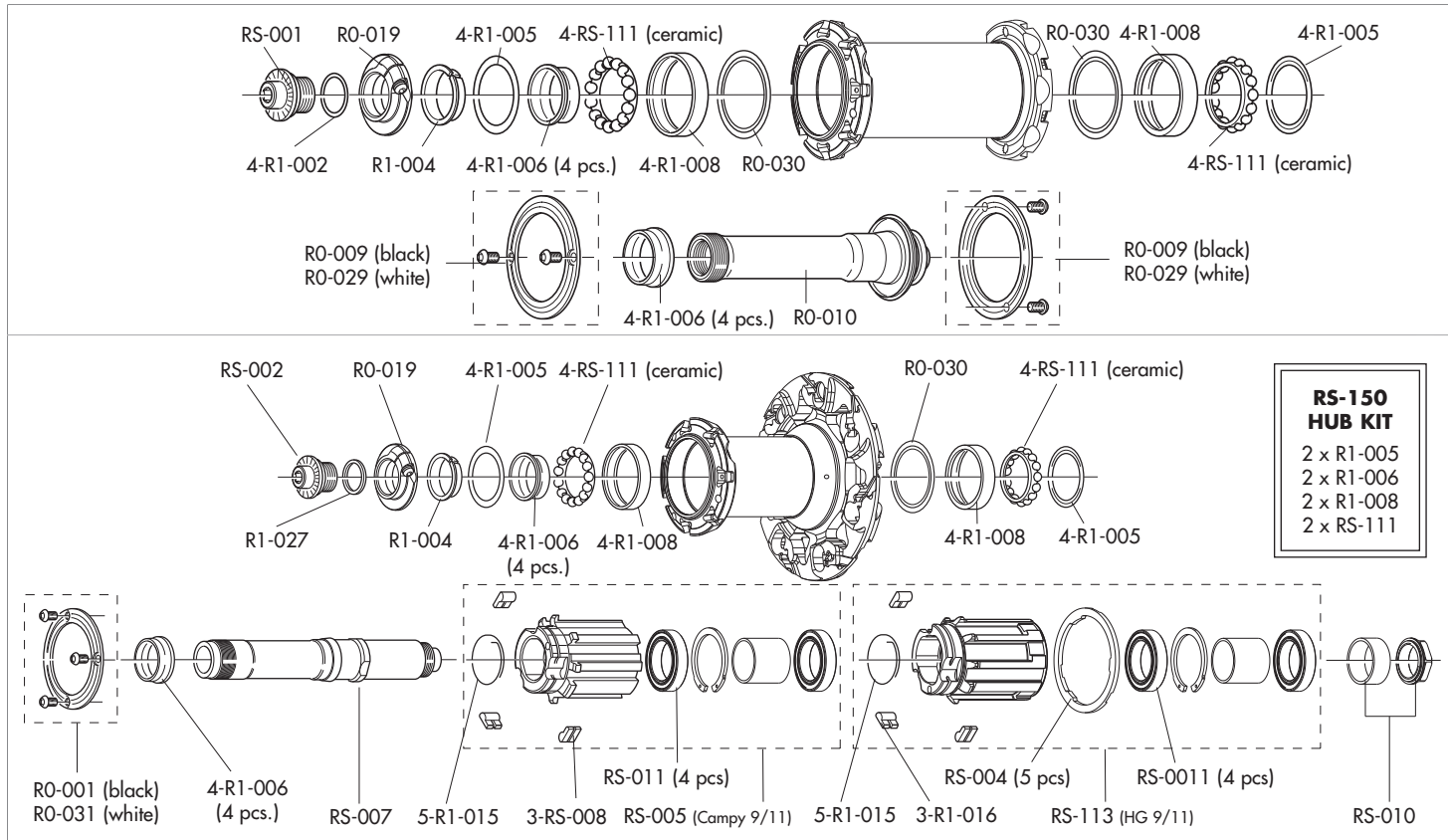

RACING 1™ 2-WAY FIT

RIMS & SPOKES/CERCHI E RAGGI

RIM

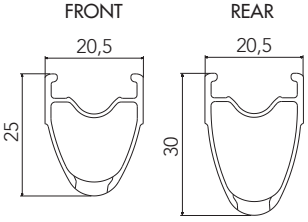
	<p>FRONT RIM REAR RIM LABEL KIT VALVE HOLE 2-Way Fit VALVE™ VALVE HOLE BUSHING DIAMETER TYRE SECTION</p>	<p>ROF-2RB11 (no labels) ROR-2RB11 (no labels) R1-LAB132B (front+rear) 6,5 mm M1-102 5-R0-014 (for valve seat reduction - 5 pcs) 634 mm See recommended tyre manufacturer inflation pressure</p>
---	--	--

SPOKES

<p>COMPLETE FRONT KIT COMPLETE REAR KIT COMPLETE FRONT COMPLETE REAR RIGHT SPOKE COMPLETE REAR LEFT SPOKE NIPPLES SPOKE RING NIPPLE INSERT NIPPLE MAGNET SPOKE SPANNER</p>	<p>ROF-SKB01 ROR-SKB11 ROF-SB01 R0-018 ROR-SB01 10-R0-015 T-02 T-03 T-05 T-07</p>	<p>16 front spokes 14 rear right spokes + 7 rear left spokes spoke + nipple spoke + nipple spoke + nipple 10 pcs anti-rotation magnet-attractor for nipple nipple-guide spoke wrench</p>
--	---	--

ACCESSORIES

<p>Spacer for HG11 FW body</p>	<p>RS-004</p>	<p>5 pcs - to be used only with 9/10s sprockets <i>(please note that every HG11 rear wheel/HG11 FW body package contains the spacer!)</i></p>
--------------------------------	---------------	---

RACING 1™ 2-WAY FIT

HUBS/MOZZI/MOYEURS

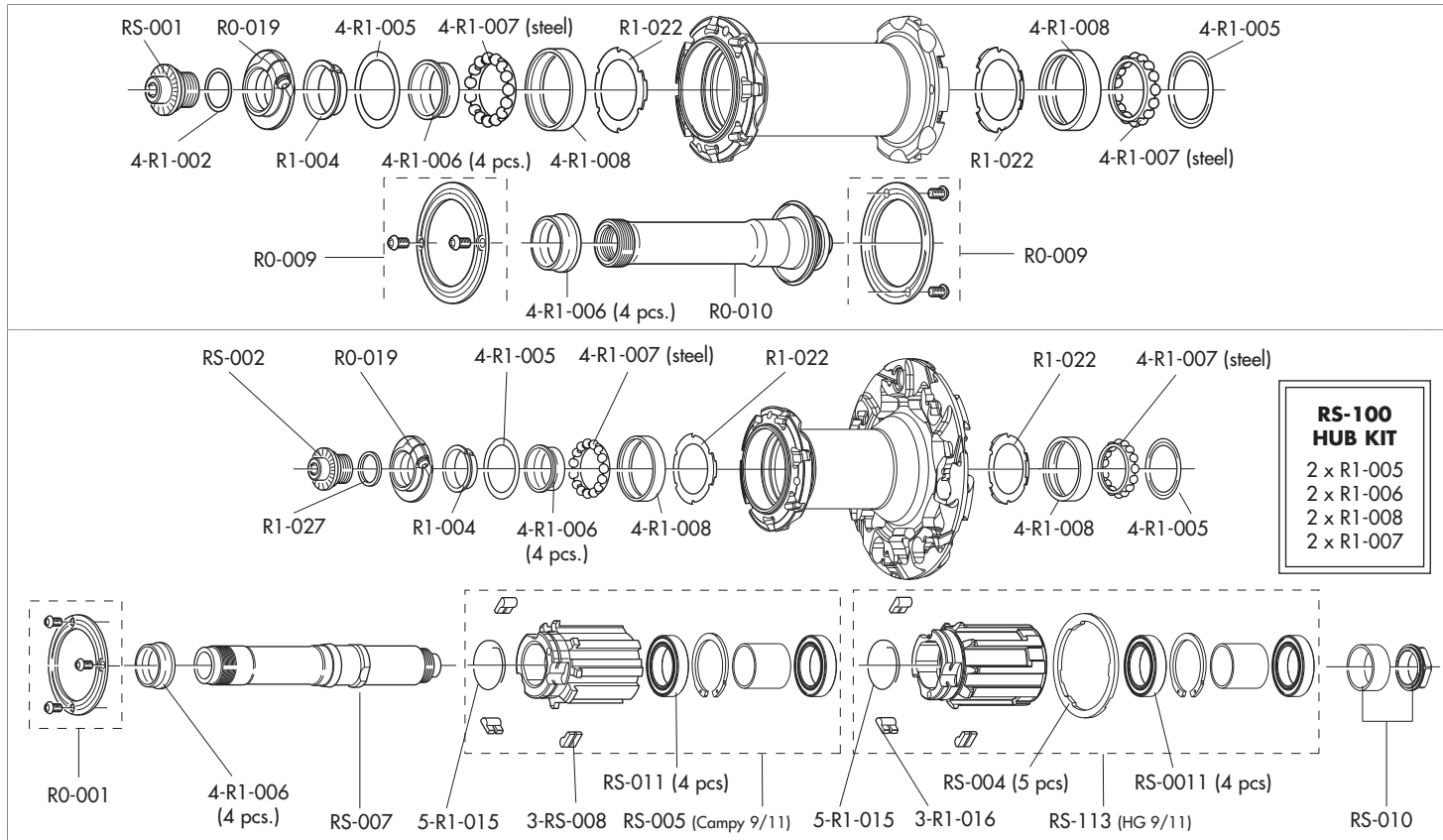

RACING 1™ CLINCHER

RIMS & SPOKES/CERCHI E RAGGI

RIM

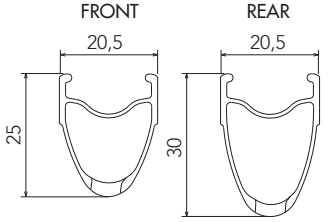
 <p>FRONT 20,5 25</p> <p>REAR 20,5 30</p>	<p>FRONT RIM REAR RIM LABEL KIT VALVE HOLE DIAMETER TYRE SECTION</p>	<p>R0F-CRB11 (no labels) R0R-CRB11 (no labels) R1-LAB13CB (front+rear) 6,5 mm 622 X 15C See section table and inflation pressures on page 66</p>
---	--	--

SPOKES

<p>COMPLETE FRONT KIT COMPLETE REAR KIT COMPLETE FRONT COMPLETE REAR RIGHT SPOKE COMPLETE REAR LEFT SPOKE NIPPLES SPOKE RING NIPPLE INSERT NIPPLE MAGNET SPOKE SPANNER</p>	<p>R0F-SKB01 R0R-SKB11 R0F-SB01 R0-018 R0R-SB01 10-R0-015 T-02 T-03 T-05 T-07</p>	<p>16 front spokes 14 rear right spokes + 7 rear left spokes spoke + nipple spoke + nipple spoke + nipple 10 pcs anti-rotation magnet-attractor for nipple nipple-guide spoke wrench</p>
--	---	--

ACCESSORIES

<p>Spacer for HG11 FW body</p>	<p>RS-004</p>	<p>5 pcs - to be used only with 9/10s sprockets <i>(please note that every HG11 rear wheel/HG11 FW body package contains the spacer)</i></p>
--------------------------------	---------------	--

RACING 1™ CLINCHER

HUBS/MOZZI/MOYEURS

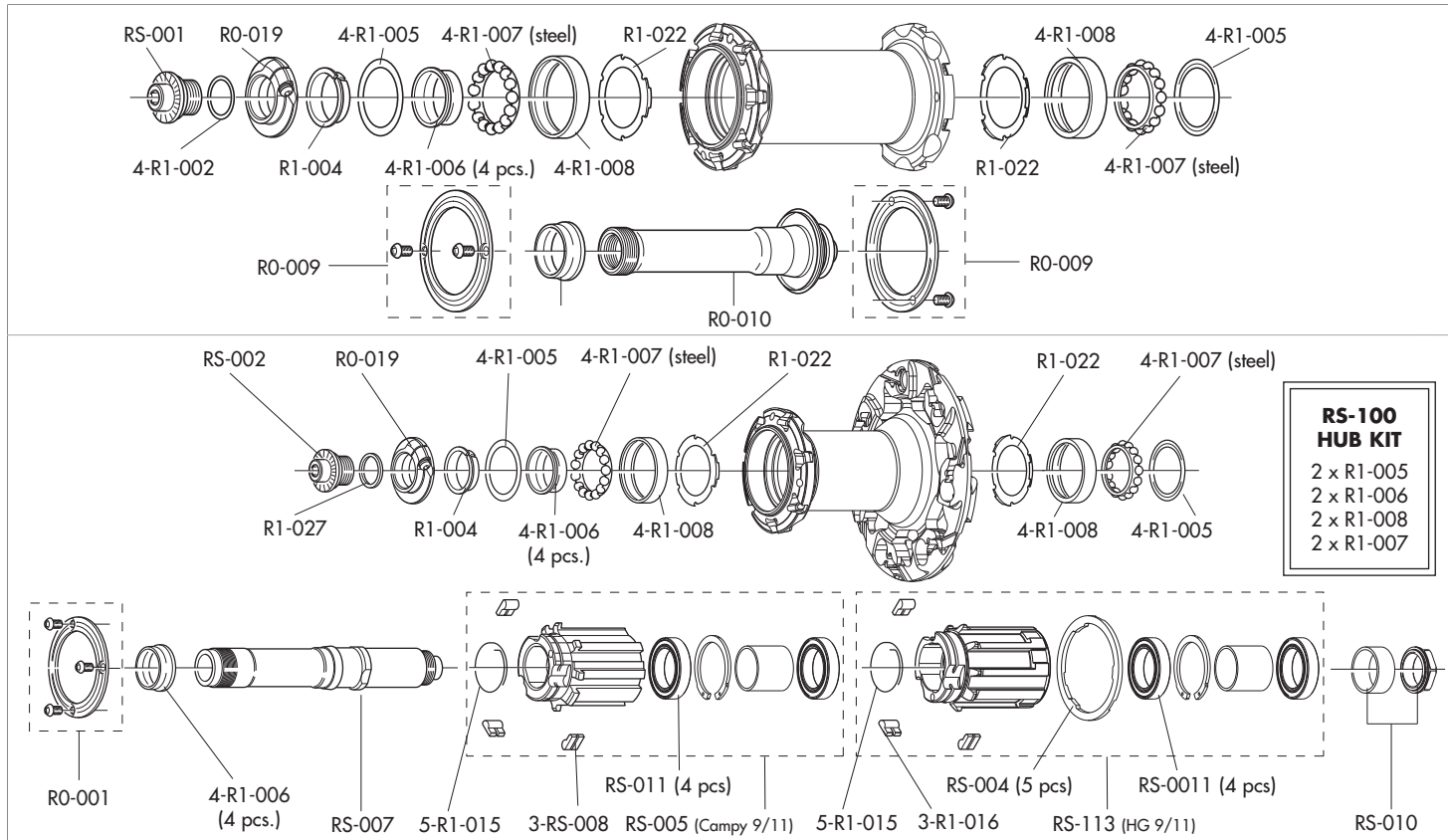

RACING 3™ 2-WAY FIT

RIMS & SPOKES/CERCHI E RAGGI

RIM

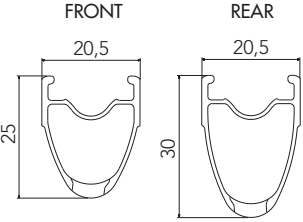
	<p>FRONT RIM REAR RIM LABEL KIT VALVE HOLE 2-Way Fit VALVE™ DIAMETER TYRE SECTION</p>	<p>R3F-2RB01 (with labels) R3R-2RB01 (with labels) R3-LAB132B (front+rear) 6,5 mm M1-102 634 mm See recommended tyre manufacturer inflation pressure</p>
---	---	--

SPOKES

<p>COMPLETE FRONT SPOKE COMPLETE REAR RIGHT SPOKE COMPLETE REAR LEFT SPOKE NIPPLES NIPPLE INSERT NIPPLE MAGNET SPOKE RING</p>	<p>R3-016 R3-018 R3-019 RM3-B T-10 T-05 T-02</p>	<p>4 spokes + 4 nipples 4 spokes + 4 nipples 4 spokes + 4 nipples 50 pcs magnet-attractor for nipple nipple-guide anti-rotation</p>
---	--	---

ACCESSORIES

<p>Spacer for HG11 FW body</p>	<p>RS-004</p>	<p>5 pcs - to be used only with 9/10s sprockets <i>(please note that every HG11 rear wheel/HG11 FW body package contains the spacer!)</i></p>
--------------------------------	---------------	---

RACING 3™ 2-WAY FIT

HUBS/MOZZI/MOYEURS

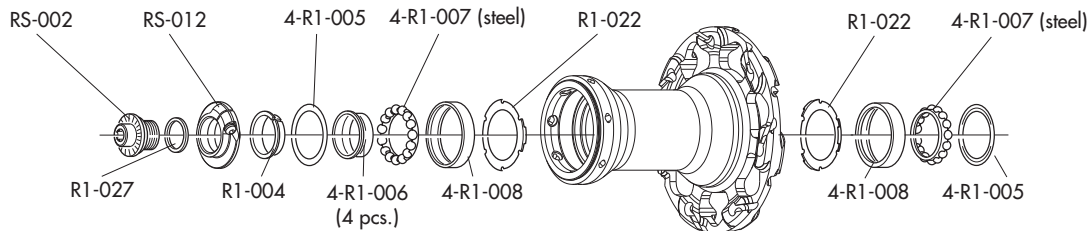
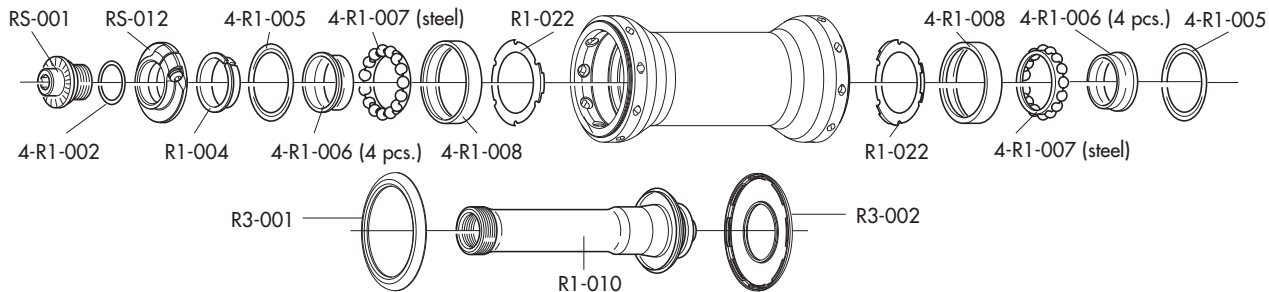

RS-100 HUB KIT
 2 x R1-005
 2 x R1-006
 2 x R1-008
 2 x R1-007

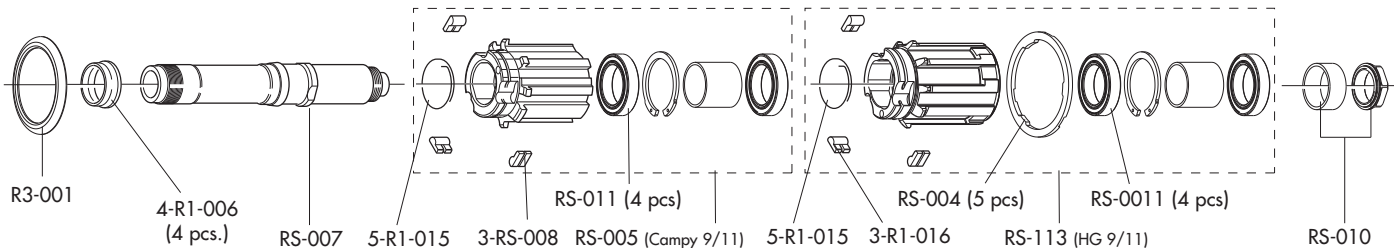

ROAD

RACING 3™ CLINCHER

RIMS & SPOKES/CERCHI E RAGGI

RIM

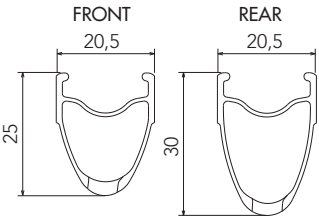
	<p>FRONT RIM REAR RIM LABEL KIT VALVE HOLE DIAMETER TYRE SECTION</p>	<p>R3F-CRB21 (with labels) R3R-CRB21 (with labels) R3-LAB13CB (front+rear) 6,5 mm 622 X 15C See section table and inflation pressures on page 66</p>
--	--	--

SPOKES

<p>COMPLETE FRONT SPOKE COMPLETE REAR RIGHT SPOKE COMPLETE REAR LEFT SPOKE NIPPLES NIPPLE INSERT NIPPLE MAGNET SPOKE RING</p>	<p>R3-016 R3-018 R3-019 RM3-B T-10 T-05 T-02</p>	<p>4 spokes + 4 nipples 4 spokes + 4 nipples 4 spokes + 4 nipples 50 pcs magnet-attractor for nipple nipple-guide anti-rotation</p>
---	--	---

ACCESSORIES

<p>Spacer for HG11 FW body</p>	<p>RS-004</p>	<p>5 pcs - to be used only with 9/10s sprockets <i>(please note that every HG11 rear wheel/HG11 FW body package contains the spacer!)</i></p>
--------------------------------	---------------	---

RACING 3™ CLINCHER

HUBS/MOZZI/MOYEURS

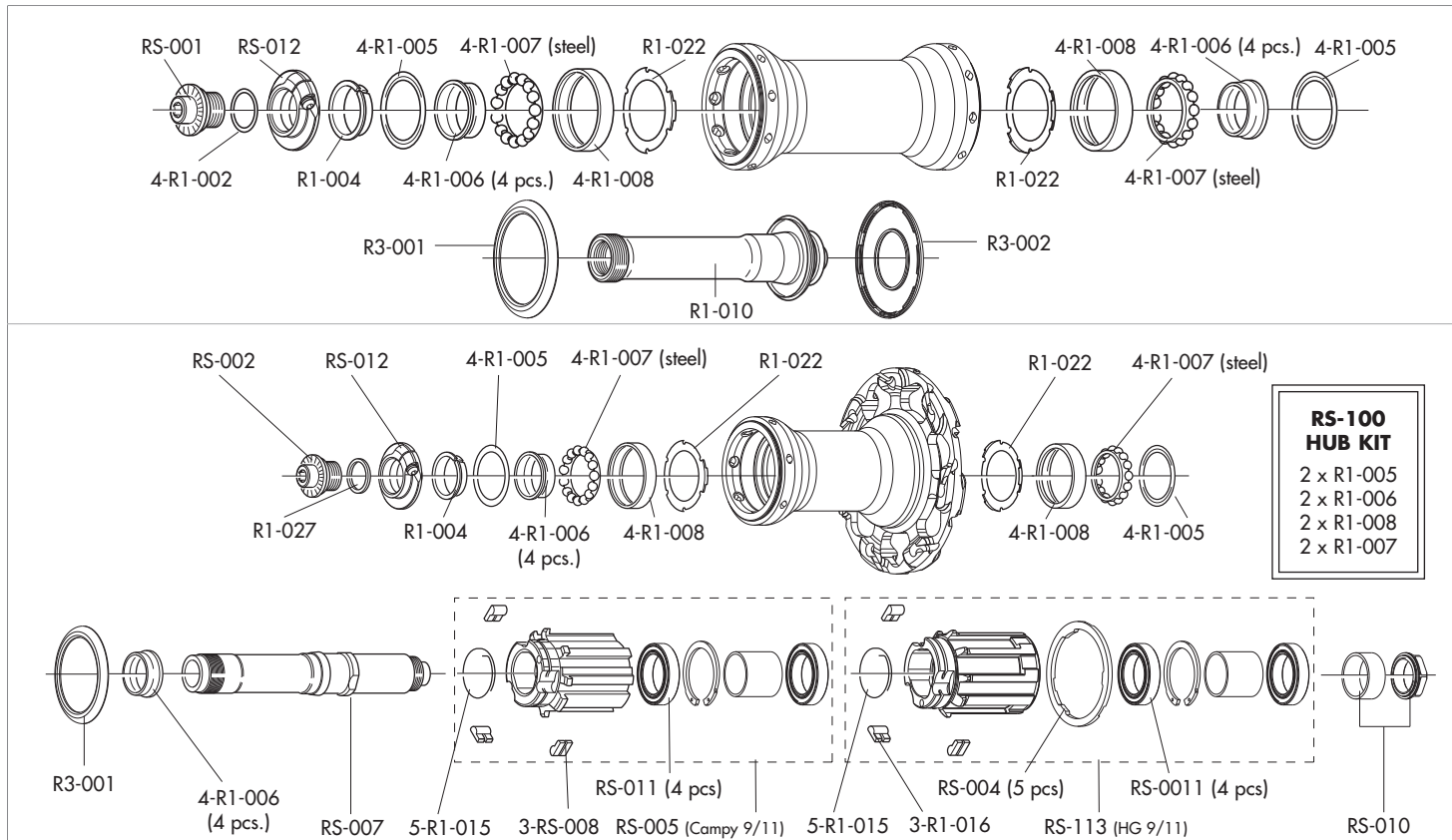

RACING QUATTRO™ CLINCHER

RIMS & SPOKES/CERCHI E RAGGI

RIM

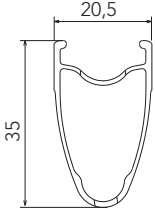
	RIM-TAPE LABEL KIT VALVE HOLE DIAMETER TYRE SECTION	2-RL-RT (18 mm - 2 pcs) R4-LAB13CB (front+rear) 6,5 mm 622 X 15C See section table and inflation pressures on page 66
---	---	---

SPOKES

FRONT SPOKE REAR RIGHT SPOKE REAR LEFT SPOKE	R4-016 R4-018 R4-019	4 spokes + 4 nipples 4 spokes + 4 nipples 4 spokes + 4 nipples
--	----------------------------	--

ACCESSORIES

Spacer for HG11 FW body	RS-004	5 pcs - to be used only with 9/10s sprockets <i>(please note that every HG11 rear wheel/HG11 FW body package contains the spacer)</i>
-------------------------	--------	--

RACING QUATTRO™ CLINCHER

HUBS/MOZZI/MOYEUX

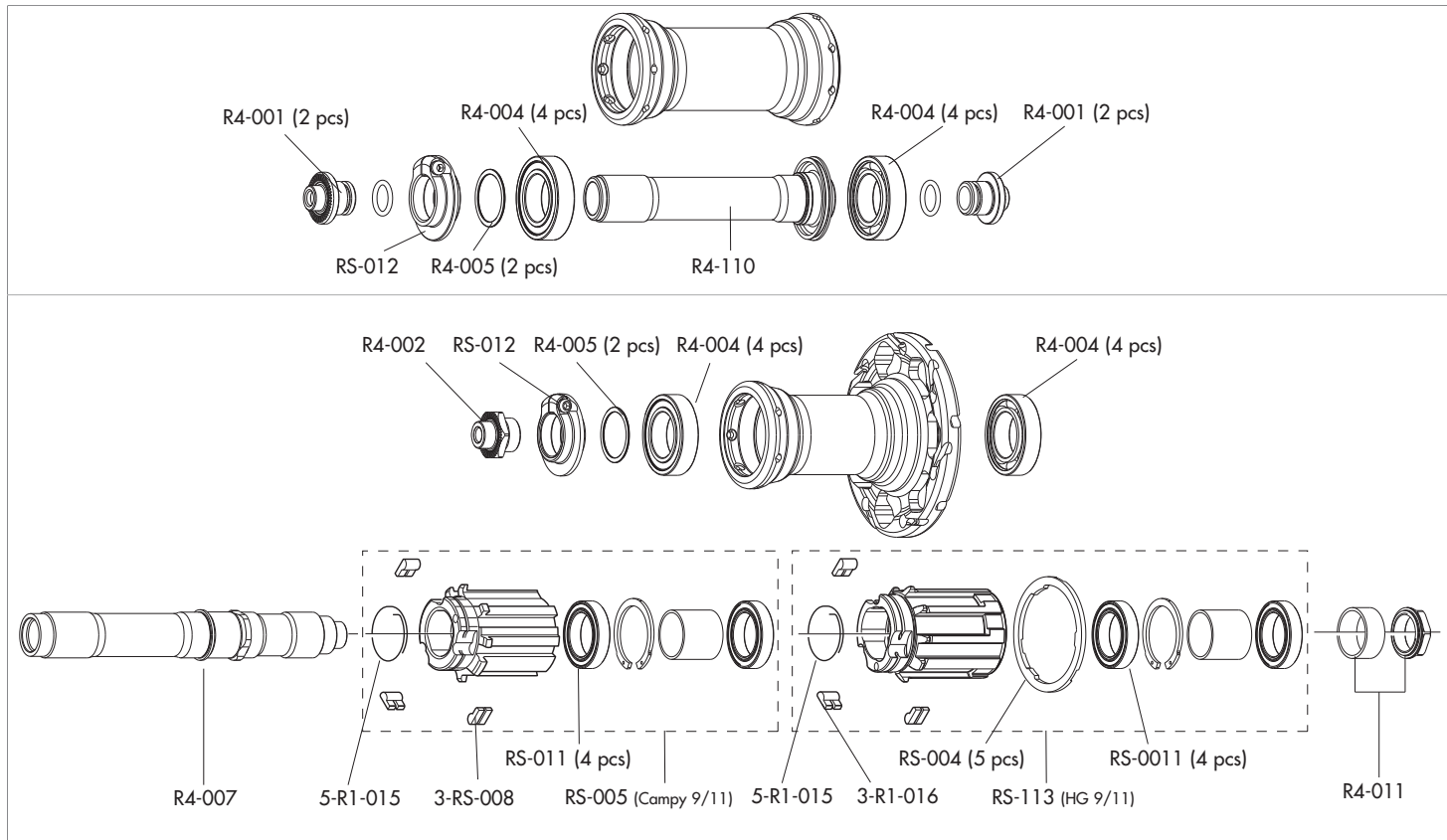

RACING 5™ CLINCHER

RIMS & SPOKES/CERCHI E RAGGI

RIM

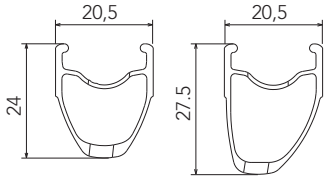
	RIM-TAPE LABEL KIT VALVE HOLE DIAMETER TYRE SECTION	2-RL-RT (18 mm - 2 pcs) R5-LAB14CB (front+rear) 6,5 mm 622 X 15C See section table and inflation pressures on page 66
--	---	---

SPOKES

FRONT SPOKE REAR RIGHT SPOKE REAR LEFT SPOKE NIPPLES	R5-216 R5-218 R5-119 R5-B	4 spokes + 4 nipples 4 spokes + 4 nipples 4 spokes + 4 nipples 50 pcs
---	------------------------------------	--

ACCESSORIES

Spacer for HG11 FW body	RS-004	5 pcs - to be used only with 9/10s sprockets <i>(please note that every HG11 rear wheel/HG11 FW body package contains the spacer!)</i>
-------------------------	--------	---

RACING 5™ CLINCHER

HUBS/MOZZI/MOYEUX

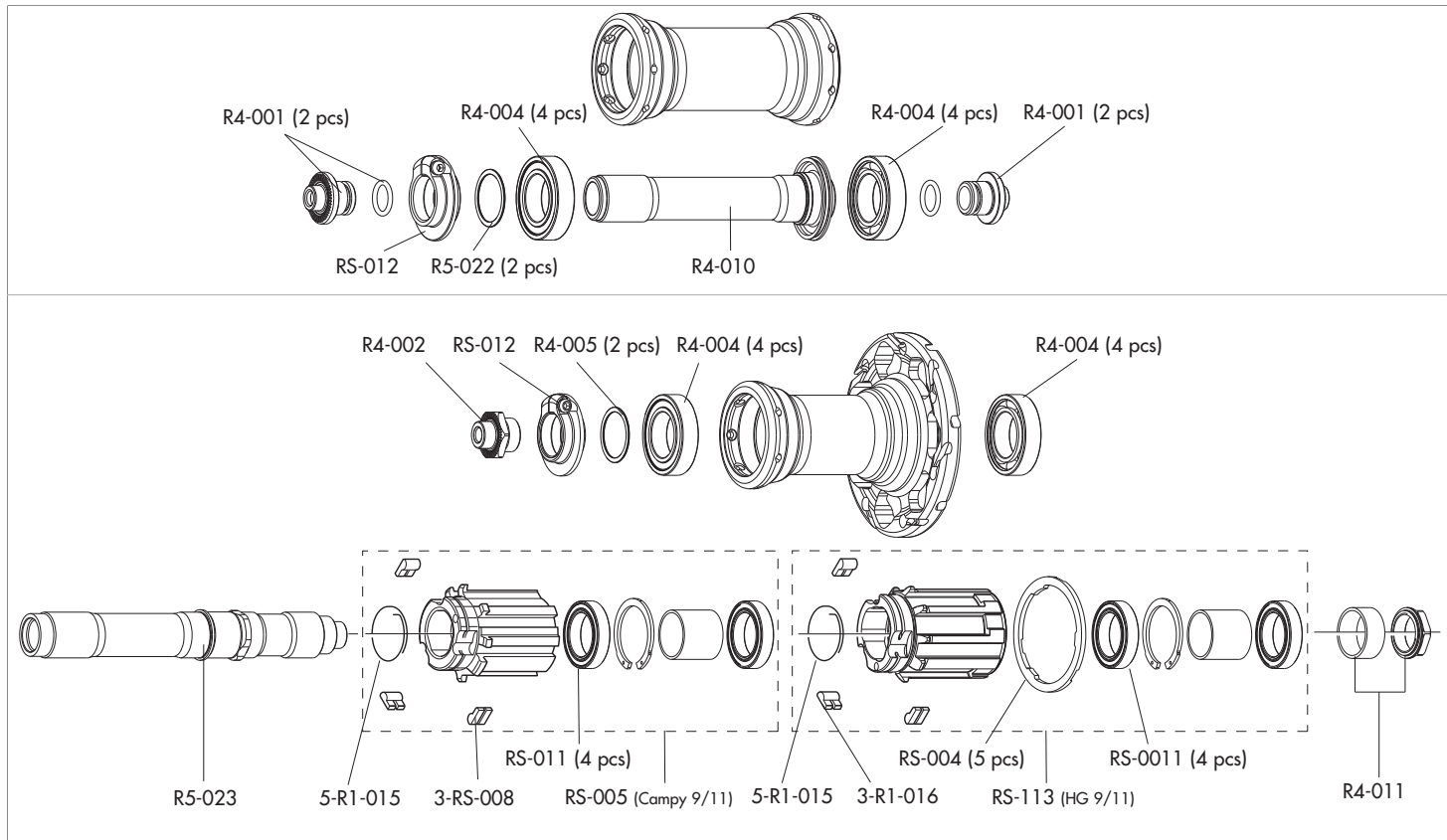

RACING 7™ CLINCHER

RIMS & SPOKES/CERCHI E RAGGI

RIM

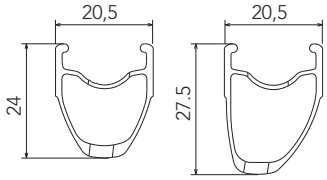
	RIM-TAPE LABEL KIT VALVE HOLE DIAMETER TYRE SECTION	2-RL-RT (18 mm - 2 pcs) R7-LAB14CB (front+rear) 6,5 mm 622 X 15C See section table and inflation pressures on page 66
--	---	---

SPOKES

FRONT SPOKE REAR RIGHT SPOKE REAR LEFT SPOKE NIPPLES	R7-116 R7-018 R7-019 RM3-B	4 spokes + 4 nipples 4 spokes + 4 nipples 4 spokes + 4 nipples 50 pcs
---	-------------------------------------	--

ACCESSORIES

Spacer for HG11 FW body	RS-004	5 pcs - to be used only with 9/10s sprockets <i>(please note that every HG11 rear wheel/HG11 FW body package contains the spacer!)</i>
-------------------------	--------	---

RACING 7™ CLINCHER

HUBS/MOZZI

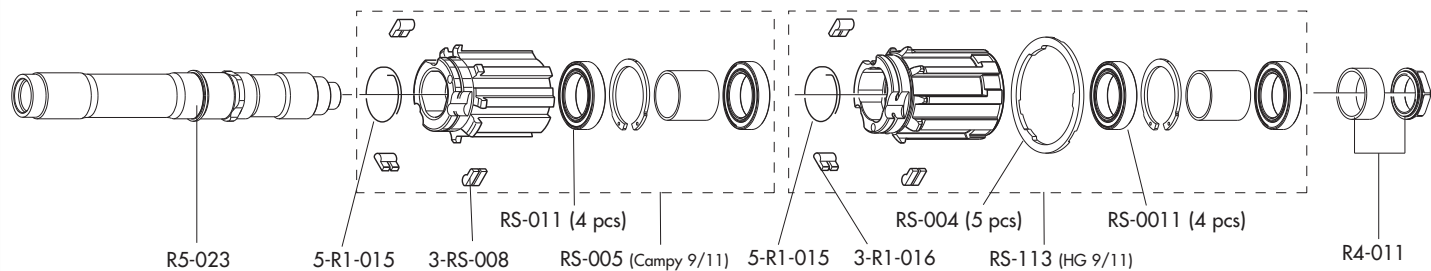
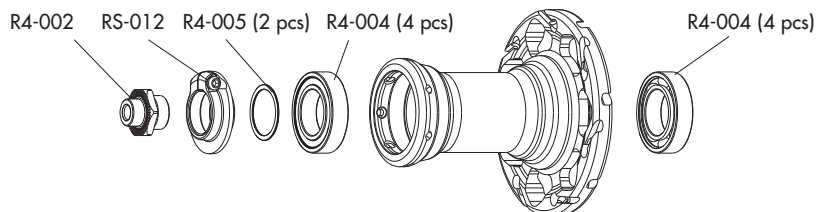
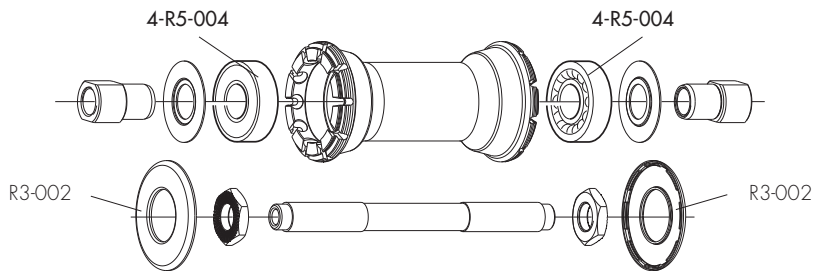

RACING SPORT™ CLINCHER

RIMS & SPOKES/CERCHI E RAGGI

RIM

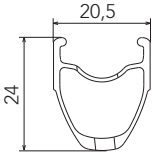
	RIM-TAPE LABEL KIT VALVE HOLE DIAMETER TYRE SECTION	2-RL-RT (18 mm - 2 pcs) RT-LAB14CB (front+rear) 6,5 mm 622 X 15C See section table and inflation pressures on page 66
---	---	---

SPOKES

FRONT SPOKE REAR RIGHT SPOKE REAR LEFT SPOKE NIPPLES	R7-116 RT-018 RT-019 RM3-B	4 spokes + 4 nipples 4 spokes + 4 nipples 4 spokes + 4 nipples 50 pcs
---	-------------------------------------	--

ACCESSORIES

Spacer for HG11 FW body	RS-004	5 pcs - to be used only with 9/10s sprockets <i>(please note that every HG11 rear wheel/HG11 FW body package contains the spacer!)</i>
-------------------------	--------	---

RACING SPORT™ CLINCHER

HUBS/MOZZI

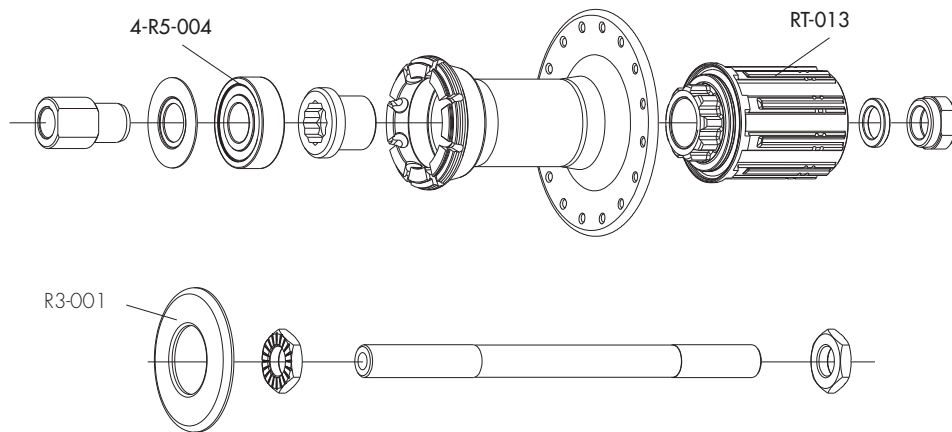
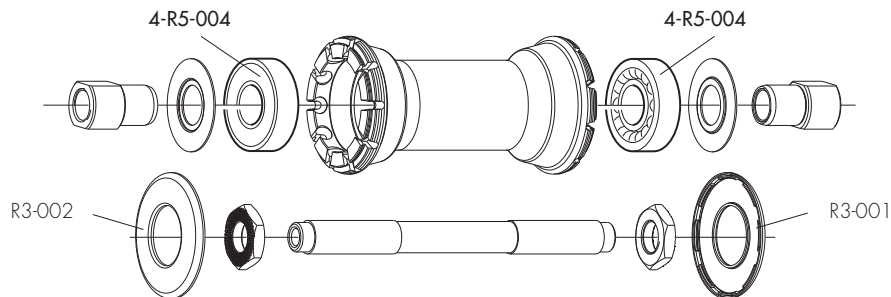

RED WIND XLR™ CLINCHER - H50

RIMS & SPOKES/CERCHI E RAGGI

RIM

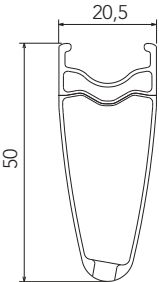
	<p>FRONT RIM REAR RIM LABEL KIT VALVE HOLE VALVE EXTENSION VALVE HOLE BUSHING DIAMETER TYRE</p>	<p>RWXF-CR (no labels) RWXR-CR (no labels) RWX-LAB13 (front+rear) - RWX-LAB13DK (front+rear DARK) 6,5 mm T-15M (male valve extension) - T-15F (female valve extension) RWX-014 (5 pcs) 700C (622 x 15C) See section table and inflation pressures on page 66</p>
---	---	--

SPOKES

<p>COMPLETE FRONT KIT COMPLETE REAR KIT MINI-KIT NIPPLES NIPPLE INSERT NIPPLE MAGNET SPOKE SPANNER SPOKE RING</p>	<p>RWXF-SK RWXR-SK RWX-MK RWX-B T-11 T-05 T-18 T-02</p>	<p>18 front spokes + 18 nipples 14 rear right spokes + 7 rear left spokes + 21 nipples 2 front spokes + 2 rear right spokes + 2 rear left spokes + 6 nipples black - 10 pcs magnet-attractor for nipple nipple-guide spoke wrench anti-rotation</p>
---	---	---

ACCESSORIES

<p>Spacer for HG11 FW body</p>	<p>RS-004</p>	<p>5 pcs - to be used only with 9/10s sprockets <i>(please note that every HG11 rear wheel/HG11 FW body package contains the spacer)</i></p>
--------------------------------	---------------	--

RED WIND XLR™ CLINCHER - H50

USB™
bearings

HUBS/MOZZI

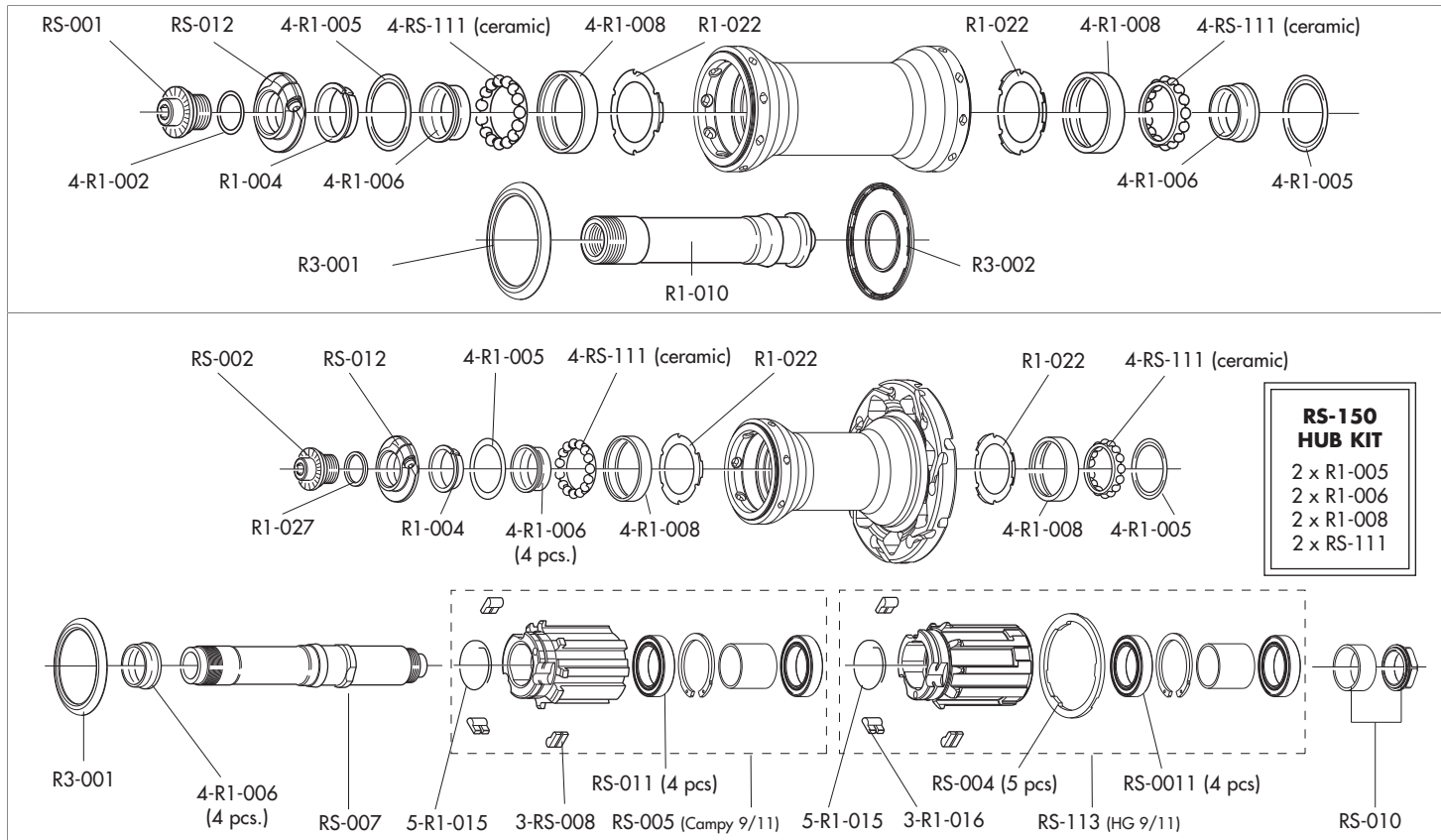

RED WIND XLR™ CLINCHER - H50

CULT™
bearings

HUBS/MOZZI

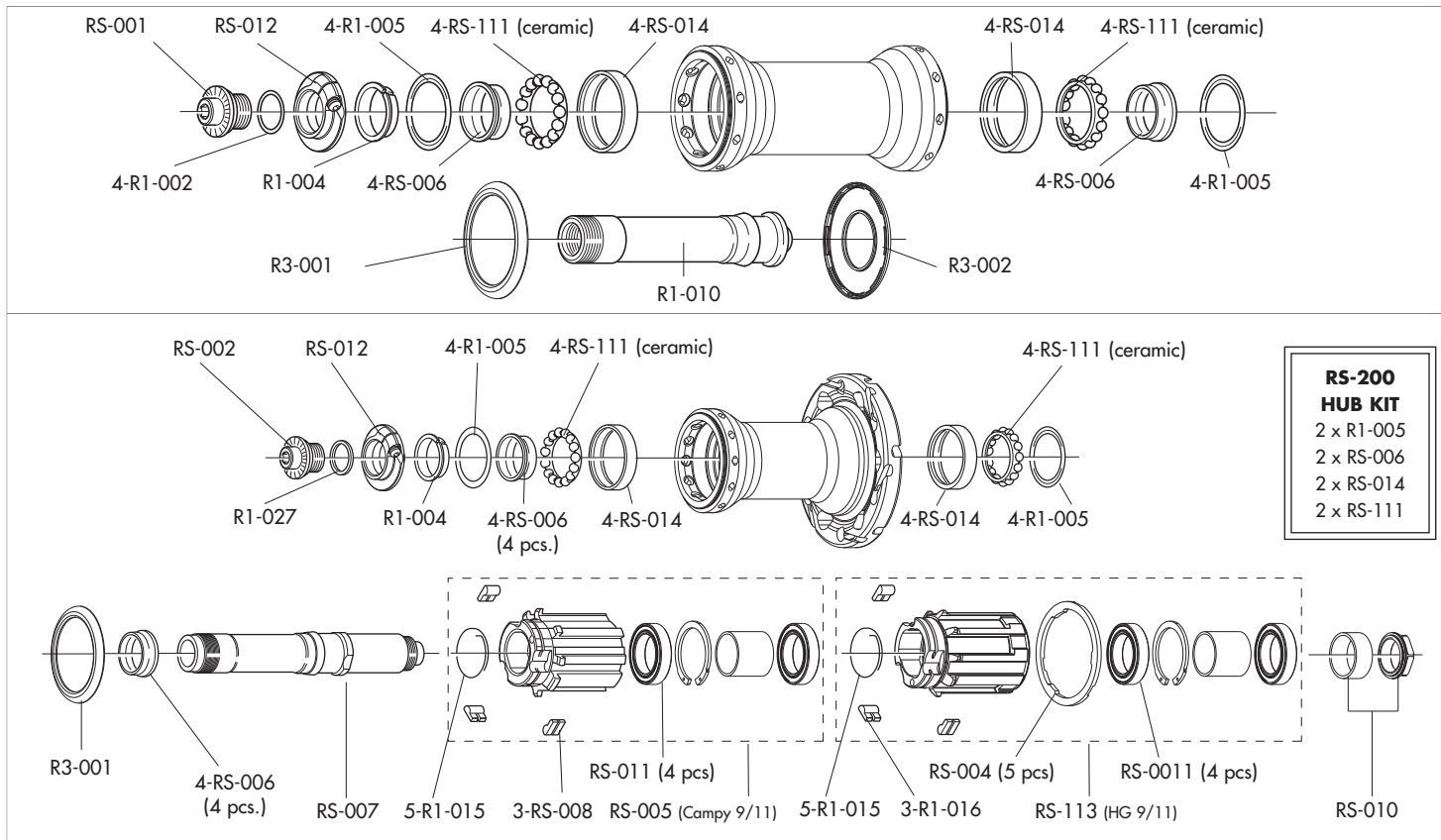

RED WIND XLR™ CLINCHER - H80

RIMS & SPOKES/CERCHI E RAGGI

RIM

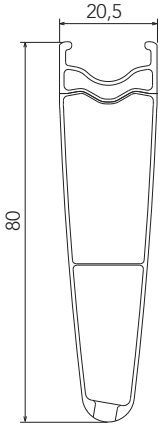
	<p>FRONT RIM REAR RIM LABEL KIT VALVE HOLE VALVE EXTENSION VALVE HOLE BUSHING DIAMETER TYRE</p>	<p>RWXF-CR80 (no labels) RWXR-CR80 (no labels) RWX-LAB1380 (front+rear) - RWX-LAB1380DK (front+rear DARK) 6,5 mm T-16M (male valve extension) - T-16F (female valve extension) RWX-014 (5 pcs) 700C (622 x 15C) See section table and inflation pressures on page 66</p>
---	--	---

SPOKES

<p>COMPLETE FRONT KIT COMPLETE REAR KIT MINI-KIT NIPPLES NIPPLE INSERT NIPPLE MAGNET SPOKE SPANNER SPOKE RING</p>	<p>RWXF-SK80 RWXR-SK80 RWX-MK80 RWX-B T-11 T-05 T-18 T-02</p>	<p>16 front spokes + 16 nipples 12 rear right spokes + 6 rear left spokes + 18 nipples 2 front spokes + 2 rear right spokes + 2 rear left spokes + 6 nipples black - 10 pcs magnet-tractor for nipple nipple-guide spoke wrench anti-rotation</p>
--	--	--

ACCESSORIES

<p>Spacer for HG11 FW body</p>	<p>RS-004</p>	<p>5 pcs - to be used only with 9/10s sprockets <i>(please note that every HG11 rear wheel/HG11 FW body package contains the spacer)</i></p>
--------------------------------	---------------	---

RED WIND XLR™ CLINCHER - H80

USB™
bearings

HUBS/MOZZI

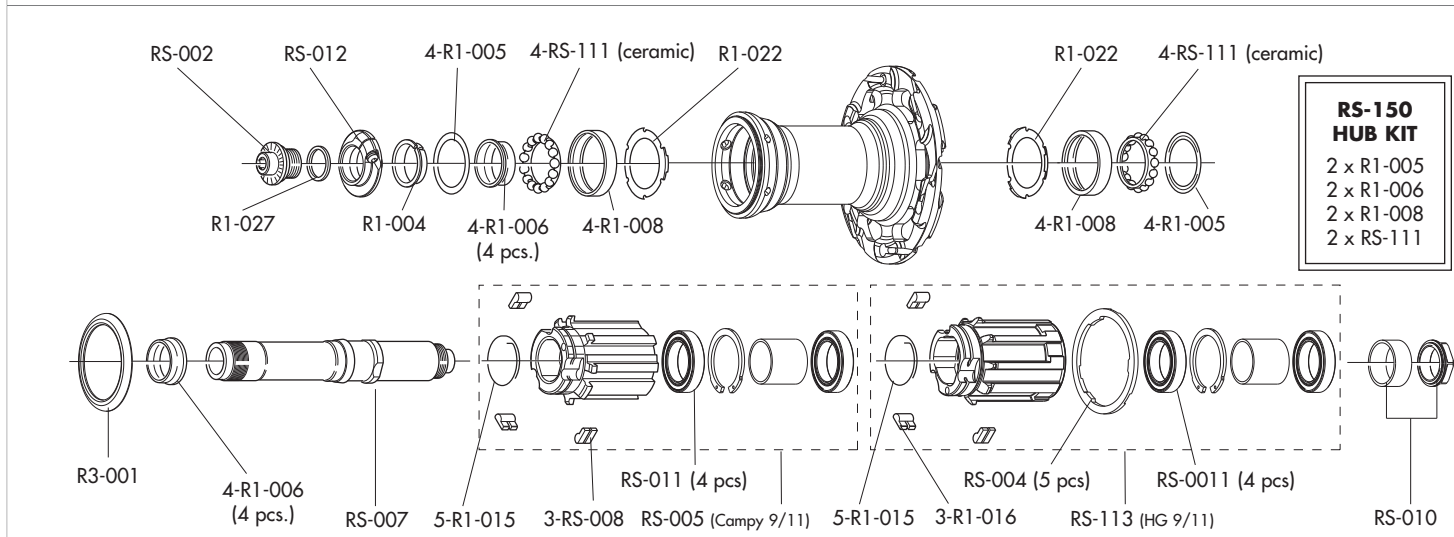
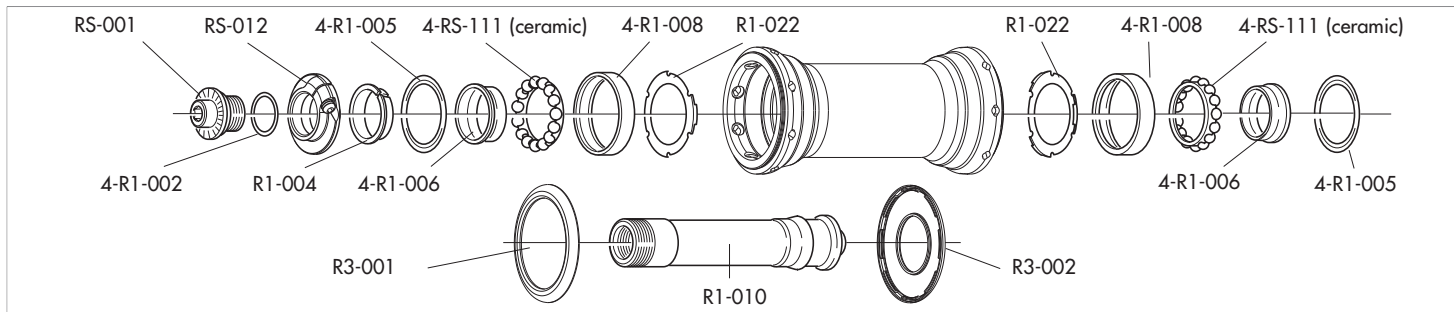

RED WIND XLR™ CLINCHER - H80

CULT™
bearings

HUBS/MOZZI

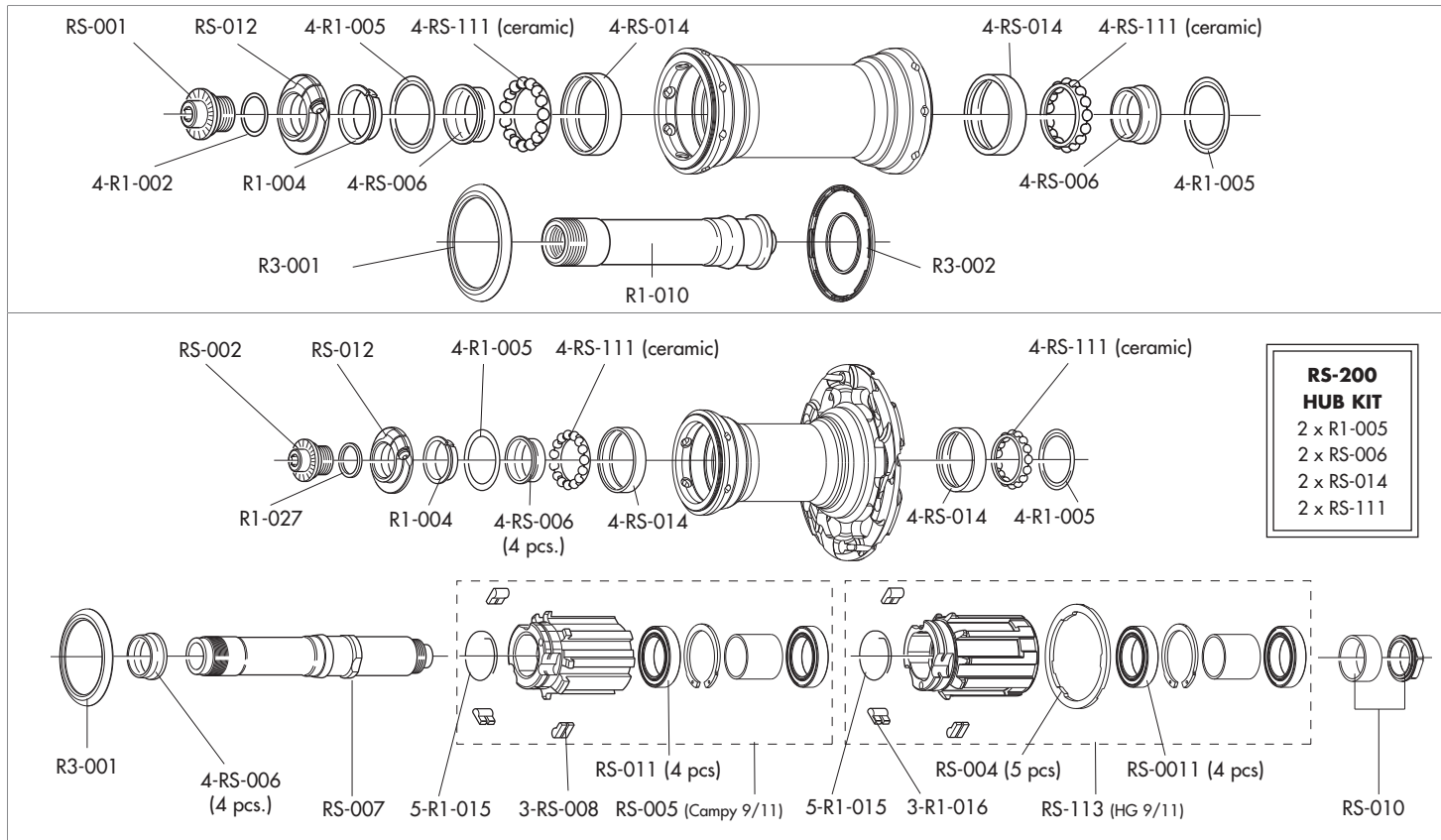

RED WIND XLR™ CLINCHER - H105

RIMS & SPOKES/CERCHI E RAGGI

RIM

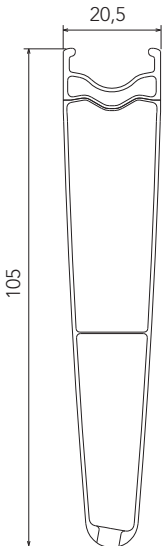
	<p>FRONT RIM REAR RIM LABEL KIT VALVE HOLE VALVE EXTENSION VALVE HOLE BUSHING DIAMETER TYRE</p>	<p>RWXF-CR105 (no labels) RWXR-CR105 (no labels) RWX-LAB13105 (front+rear) - RWX-LAB13105DK (front+rear DARK) 6,5 mm T-17M (male valve extension) - T-17F (female valve extension) RWX-014 (5 pcs) 700C (622 x 15C) See section table and inflation pressures on page 4</p>
---	---	---

SPOKES

<p>COMPLETE FRONT KIT COMPLETE REAR KIT MINI-KIT NIPPLES NIPPLE INSERT NIPPLE MAGNET SPOKE SPANNER</p>	<p>RWXF-SK105 RWXR-SK105 RWX-MK105 RWX-B T-11 T-05 T-18</p>	<p>16 front spokes + 16 nipples 12 rear right spokes + 6 rear left spokes + 18 nipples 2 front spokes + 2 rear right spokes + 2 rear left spokes + 6 nipples black - 10 pcs magnet-tractor for nipple nipple-guide spoke wrench</p>
--	---	---

ACCESSORIES

Spacer for HG11 FW body	RS-004	5 pcs - to be used only with 9/10s sprockets <i>(please note that every HG11 rear wheel/HG11 FW body package contains the spacer)</i>
-------------------------	--------	---

RED WIND XLR™ CLINCHER - H105

CULT™
bearings

HUBS/MOZZI

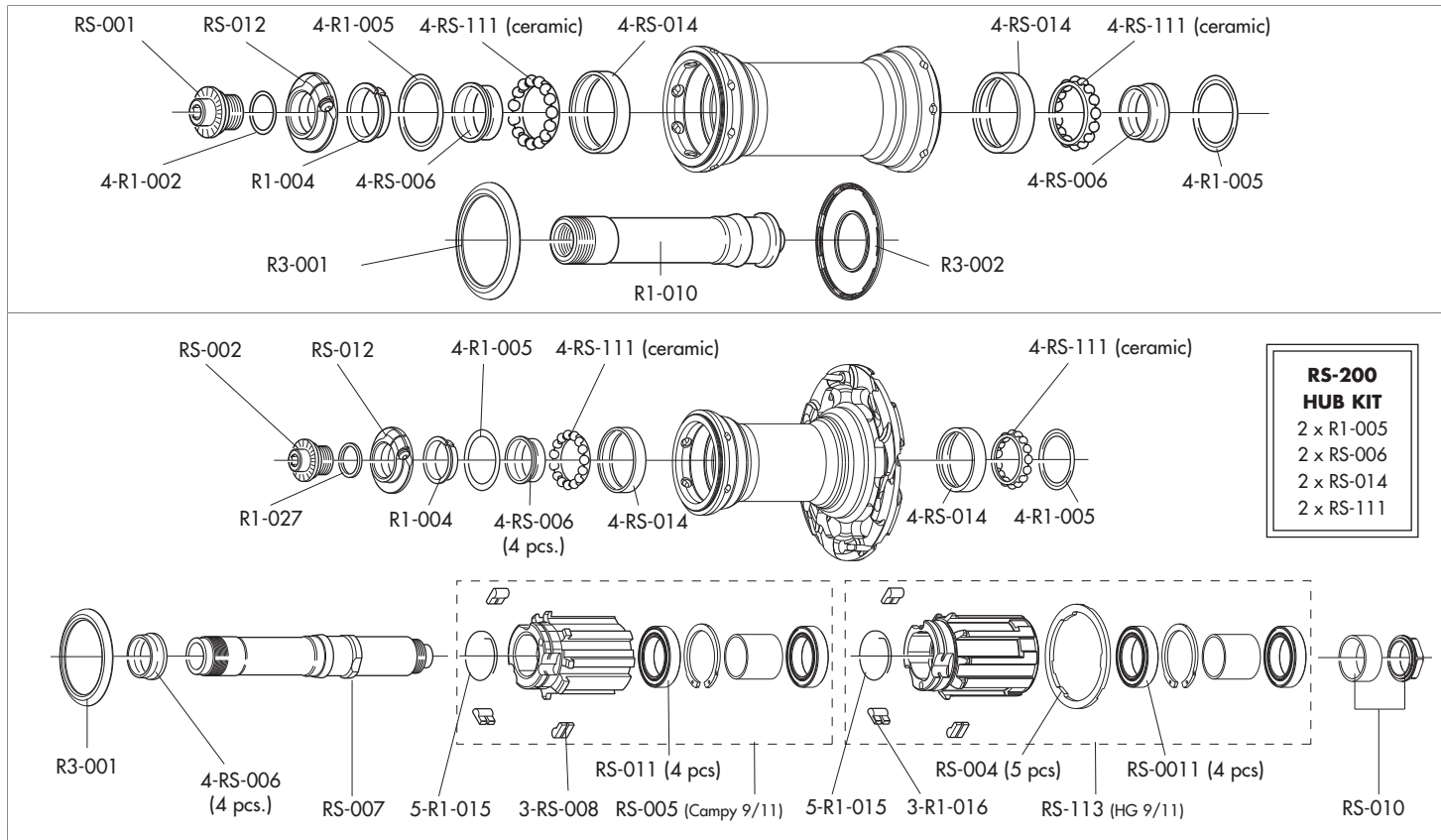

RED WIND™ CLINCHER - H50

RIMS & SPOKES/CERCHI E RAGGI

RIM

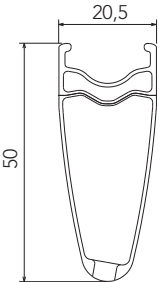
	<p>FRONT RIM REAR RIM LABEL KIT VALVE HOLE VALVE EXTENSION VALVE HOLE BUSHING DIAMETER TYRE</p>	<p>RWXF-CR (no labels) RWXR-CR (no labels) RWI-LAB12 (front+rear) 6,5 mm T-15M (male valve extension) - T-15F (female valve extension) RWX-014 (5 pcs) 700C (622 x 15C) See section table and inflation pressures on page 66</p>
---	--	---

SPOKES

<p>COMPLETE FRONT KIT COMPLETE REAR KIT MINI-KIT NIPPLES NIPPLE INSERT NIPPLE MAGNET SPOKE SPANNER SPOKE RING</p>	<p>RWIF-SK RWIR-SK RWI-MK RWI-B T-11 T-05 T-18 T-02</p>	<p>18 front spokes + 18 nipples 14 rear right spokes + 7 rear left spokes + 21 nipples 2 front spokes + 2 rear right spokes + 2 rear left spokes + 6 nipples 10 pcs magnet-attractor for nipple nipple-guide spoke wrench anti-rotation</p>
--	--	--

ACCESSORIES

<p>Spacer for HG11 FW body</p>	<p>RS-004</p>	<p>5 pcs - to be used only with 9/10s sprockets <i>(please note that every HG11 rear wheel/HG11 FW body package contains the spacer)</i></p>
--------------------------------	---------------	---

RED WIND™ CLINCHER - H50

standard bearings

HUBS/MOZZI

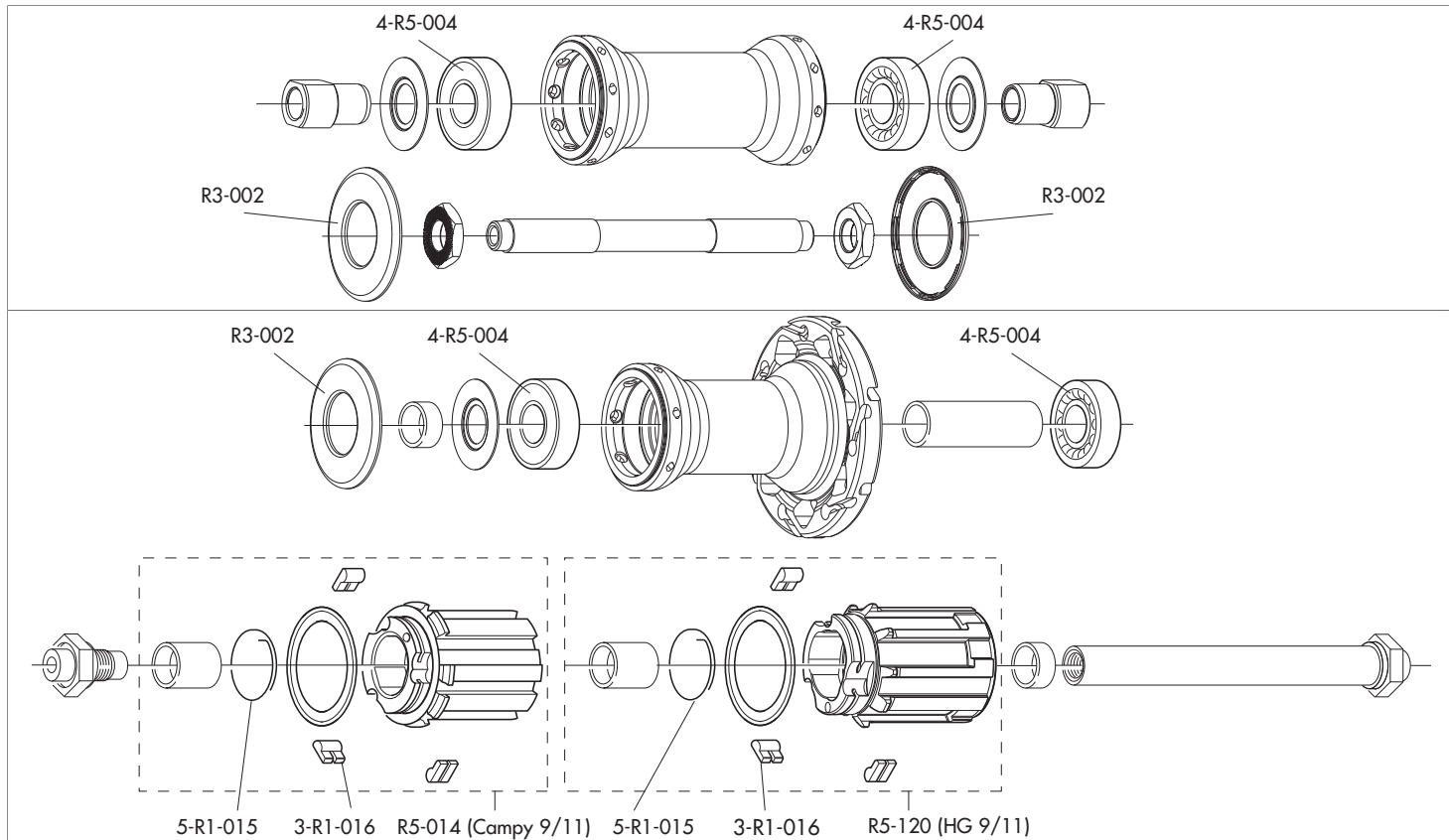

RED WIND™ CLINCHER - H50

USB™
bearings

HUBS/MOZZI

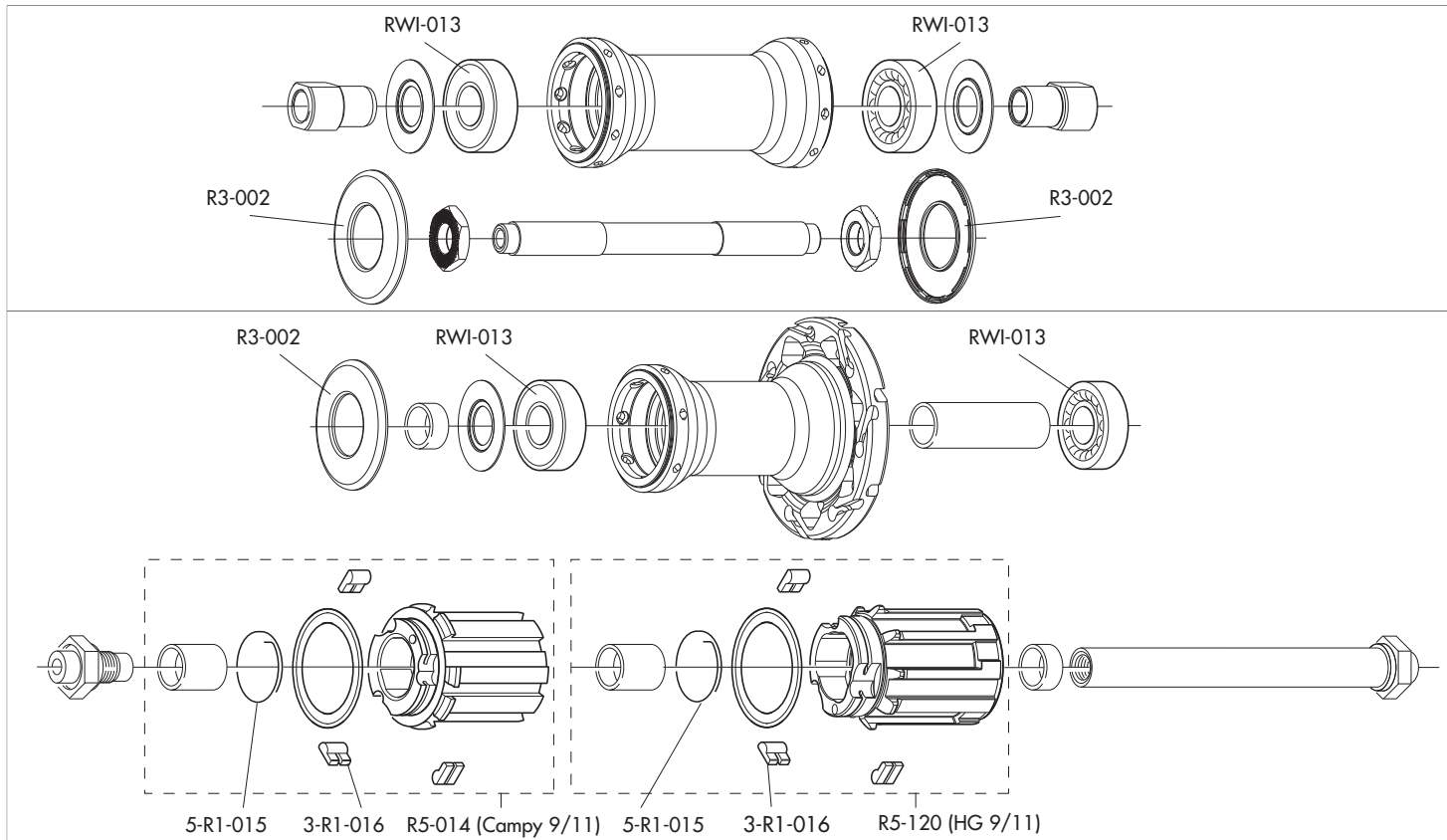

RACING LIGHT™ XLR clincher

RIMS & SPOKES/CERCHI E RAGGI

RIM

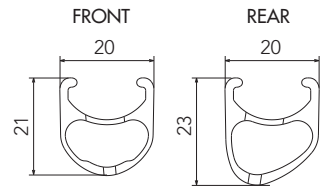
	<p>FRONT RIM REAR RIM RIM-TAPE LABEL KIT VALVE HOLE DIAMETER TYRE SECTION BRAKE SHOES CLINCHER REMOVAL LEVER</p>	<p>RLF-CRK01 (with labels) RLR-CRK01 (with labels) 2-RL-RT (16 mm - 2 pcs) RL-LAB9C (for a pair of front+rear wheels) 6,5 mm 622 X 13C See section table and inflation pressures on page 66 for carbon rims - BR-BO500 (for Campagnolo brakes) - BR-BO500X (for Shimano brakes) WH-109HYC (6 pcs.)</p>
--	--	---

SPOKES

<p>COMPLETE FRONT KIT COMPLETE REAR KIT MINI-KIT NUTS FRONT NUT SUPP. PLATES REAR NUT SUPP. PLATES</p>	<p>RLF-SK RLR-SK01 RL-MK01 RS-B RL-CF RL-CR</p>	<p>22 front/rear left spokes + 22 nuts + 22 front nut supporting plates 16 rear right spokes + 8 front/rear left spokes + 24 nuts + 24 rear nut supporting plates 3 front/rear left spokes + 2 rear right spokes + 5 nuts + 2 front nut supp. plates + 3 rear nut supp. plates 10 pcs 10 pcs 10 pcs</p>
--	---	---

ACCESSORIES

<p>Spacer for HG11 FW body</p>	<p>RS-004</p>	<p>5 pcs - to be used only with 9/10s sprockets <i>(please note that every HG11 rear wheel/HG11 FW body package contains the spacer)</i></p>
--------------------------------	---------------	--

RACING LIGHT™ XLR clincher

HUBS/MOZZI

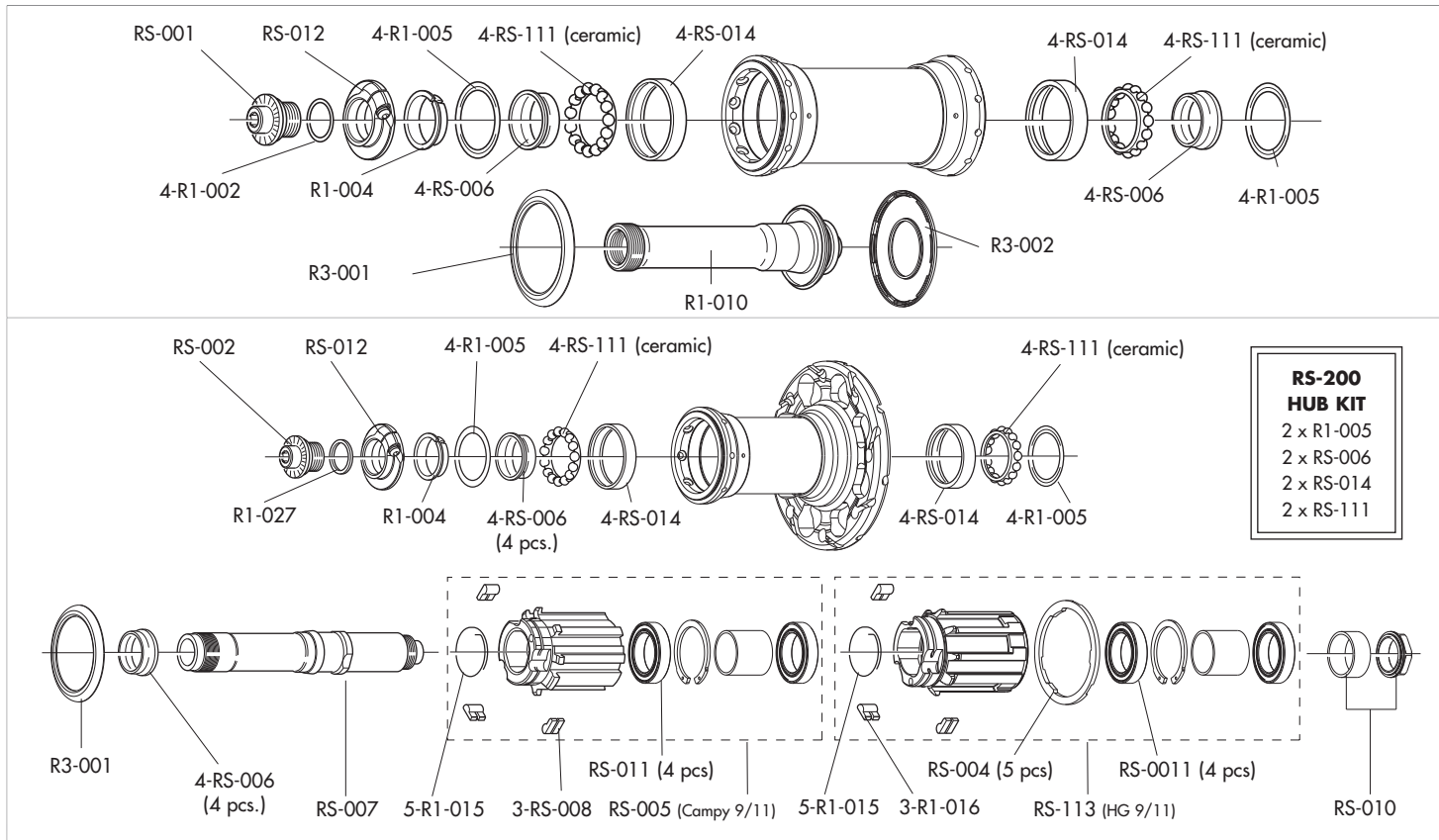

RACING LIGHT™ XLR tubular

RIMS & SPOKES/CERCHI E RAGGI

RIM

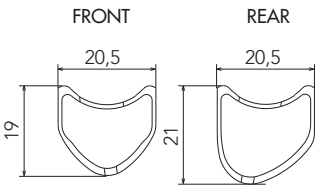
	<p>FRONT RIM REAR RIM LABEL KIT VALVE HOLE DIAMETER TYRE SECTION BRAKE SHOES</p>	<p>RLF-TRK01 (with labels) RLR-TRK01 (with labels) RL-LAB9T (for a pair of front+rear wheels) 6,5 mm 634 mm See recommended tyre manufacturer inflation pressure for carbon rims - BR-BO500 (for Campagnolo brakes) - BR-BO500X (for Shimano brakes)</p>
--	--	--

SPOKES

<p>COMPLETE FRONT KIT COMPLETE REAR KIT MINI-KIT NUTS Nut supporting plates</p>	<p>RLF-TSK01 RLR-TSK01 RL-TMK01 RS-B RL-CF</p>	<p>22 front/rear left spokes + 22 nuts + 22 front nut supporting plates 16 rear right spokes + 8 front/rear left spokes + 24 nuts + 24 rear nut supporting plates 3 front /rear left spokes + 2 rear right spokes + 5 nuts + 5 nut supporting plates 10 pcs 10 pcs</p>
---	--	--

ACCESSORIES

<p>Spacer for HG11 FW body</p>	<p>RS-004</p>	<p>5 pcs - to be used only with 9/10s sprockets <i>(please note that every HG11 rear wheel/HG11 FW body package contains the spacer)</i></p>
--------------------------------	---------------	--

RACING LIGHT™ XLR tubular

HUBS/MOZZI

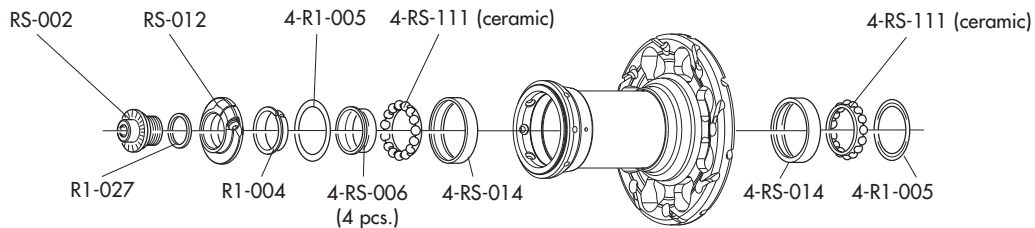
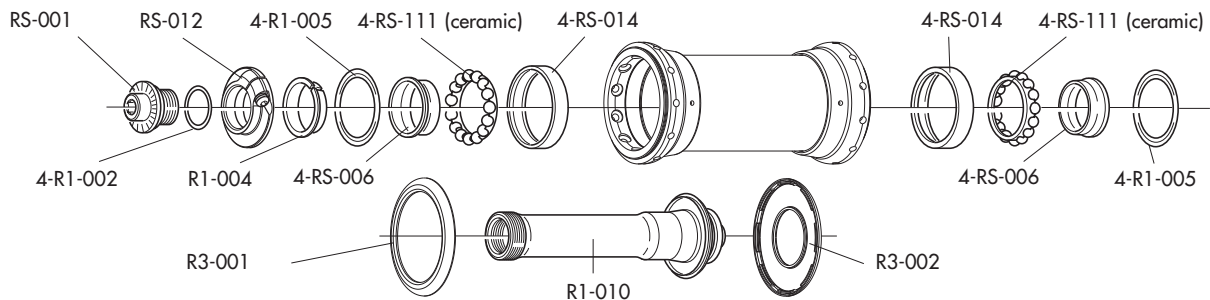

<p>RS-200 HUB KIT</p> <p>2 x R1-005 2 x RS-006 2 x RS-014 2 x RS-111</p>

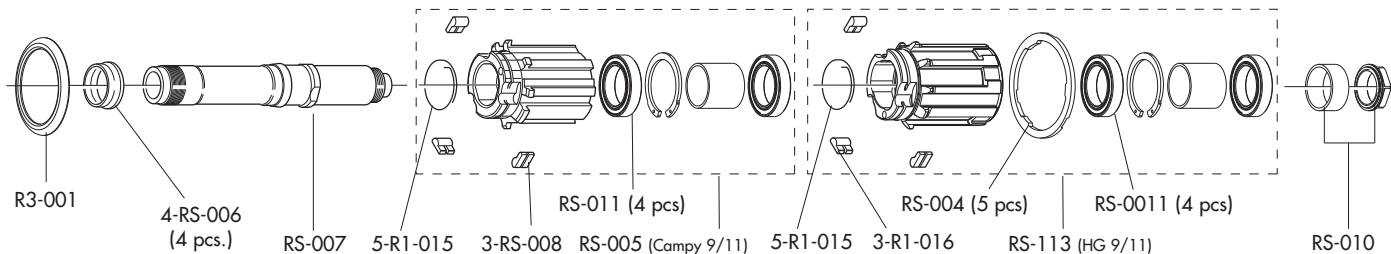

RACING SPEED™ XLR 35 tubular

RIMS & SPOKES/CERCHI E RAGGI

RIM

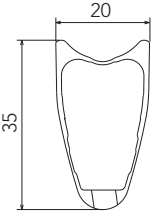
	<p>FRONT RIM REAR RIM LABEL KIT VALVE HOLE DIAMETER TYRE</p> <p>BRAKE SHOES</p>	<p>RSF-TRK3514 (no labels) RSR-TRK3514 (no labels) RS-LAB14T35 (front+rear) - RS-LAB14TDK35 (DARK front+rear) 6,5 mm 634 mm</p> <p>See recommended tyre manufacturer inflation pressure / vedi pressione di gonfiaggio consigliata dal produttore del pneumatico for carbon rims - BR-BO500 (for Campagnolo brakes) - BR-BO500X (for Shimano brakes)</p>
---	---	--

SPOKES

<p>FRONT SPOKE REAR RIGHT SPOKE REAR LEFT SPOKE NIPPLES NIPPLE INSERT NIPPLE MAGNET SPOKE SPANNER SPOKE RING</p>	<p>RS-01635 RS-01835 RS-01935 RWX-B T-11 T-05 T-18 T-02</p>	<p>4 spokes + 4 nipples 4 spokes + 4 nipples 4 spokes + 4 nipples black - 10 pcs magnet-attractor for nipple nipple-guide spoke wrench anti-rotation</p>
--	---	--

ACCESSORIES

<p>Spacer for HG11 FW body</p>	<p>RS-004</p>	<p>5 pcs - to be used only with 9/10s sprockets <i>(please note that every HG11 rear wheel/HG11 FW body package contains the spacer)</i></p>
--------------------------------	---------------	--

WARNING!

Because of the high temperatures reached when braking, we recommend you use only glue for tubular tires specifically for carbon fibre rims.
A causa delle alte temperature raggiunte in frenata, vi consigliamo di utilizzare solamente colla per tubolari che sia specifica per i soli cerchi in fibra di carbonio.

RACING SPEED™ XLR 35 tubular

HUBS/MOZZI

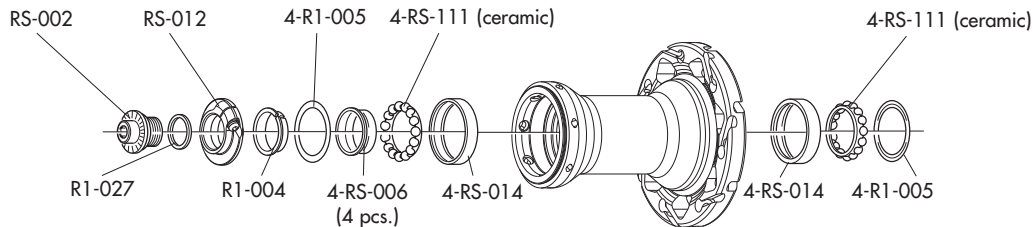
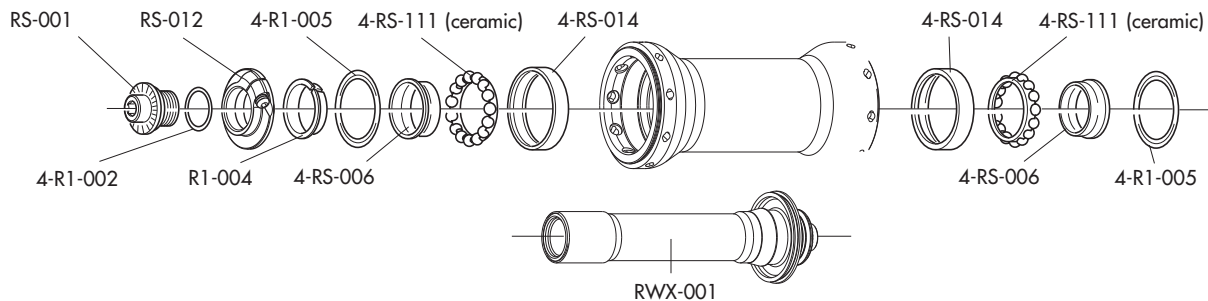

RS-200 HUB KIT
2 x R1-005
2 x RS-006
2 x RS-014
2 x RS-111

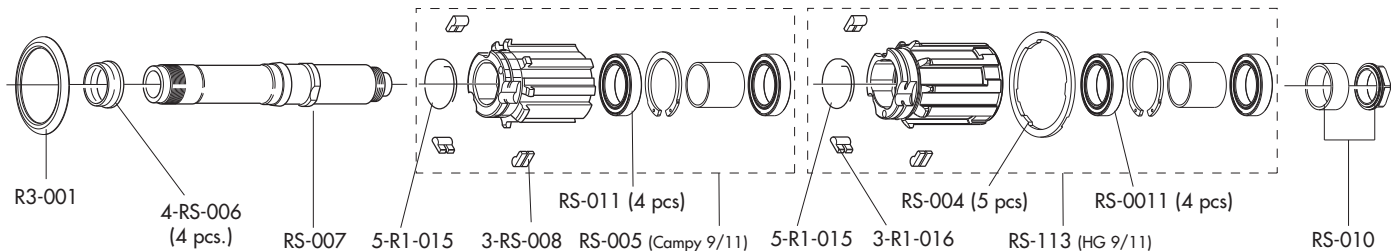

RACING SPEED™ XLR tubular

RIMS & SPOKES/CERCHI E RAGGI

RIM

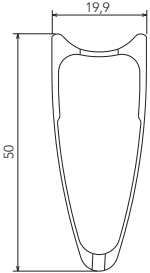
	<p>FRONT RIM REAR RIM LABEL KIT VALVE HOLE VALVE EXTENSION DIAMETER TYRE</p> <p>BRAKE SHOES</p>	<p>RSF-TRK11 (no labels) RSR-TRK11 (no labels) RS-LAB9T (front+rear) - RS-LAB12TDK (DARK front+rear) 6,5 mm T-08 634 mm See recommended tyre manufacturer inflation pressure / vedi pressione di gonfiaggio consigliata dal produttore del pneumatico for carbon rims - BR-BO500 (for Campagnolo brakes) - BR-BO500X (for Shimano brakes)</p>
---	---	---

SPOKES

<p>COMPLETE FRONT KIT COMPLETE REAR KIT MINI-KIT NUTS NUT SUPPORTING PLATES SPOKE RING</p>	<p>RSF-SK RSR-SK01 RS-MK01 RS-B RS-C T-02</p>	<p>18 front spokes + 18 nuts + 18 nut supporting plates 14 rear right spokes + 7 rear left spokes + 21 nuts + 21 nut supporting plates 2 front spokes + 2 rear right spokes + 1 rear left spokes + 5 nuts + 5 nut supporting plates 10 pcs 10 pcs anti-rotation</p>
--	---	---

ACCESSORIES

Spacer for HG11 FW body	RS-004	5 pcs - to be used only with 9/10s sprockets <i>(please note that every HG11 rear wheel/HG11 FW body package contains the spacer)</i>
-------------------------	--------	--

WARNING!

Because of the high temperatures reached when braking, we recommend you use only glue for tubular tires specifically for carbon fibre rims.
A causa delle alte temperature raggiunte in frenata, vi consigliamo di utilizzare solamente colla per tubolari che sia specifica per i soli cerchi in fibra di carbonio.

RACING SPEED™ XLR tubular

HUBS/MOZZI

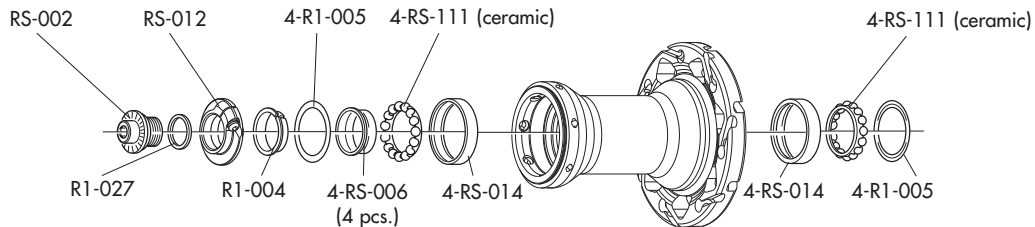
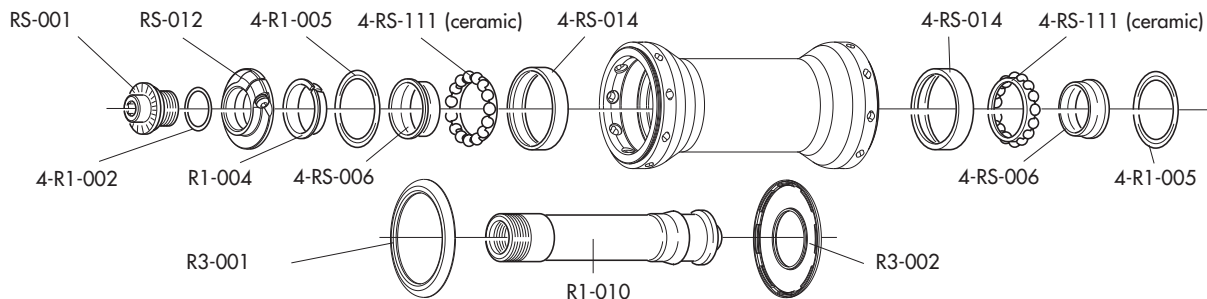

<p>RS-200 HUB KIT</p> <ul style="list-style-type: none"> 2 x R1-005 2 x RS-006 2 x RS-014 2 x RS-111

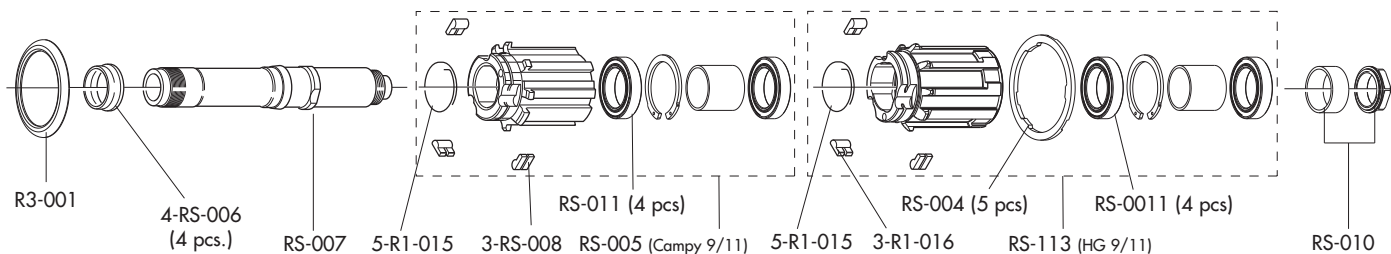

RACING SPEED™ XLR 80 tubular

RIMS & SPOKES/CERCHI E RAGGI

RIM

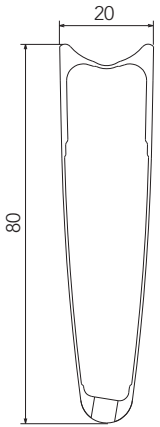
	<p>FRONT RIM REAR RIM LABEL KIT VALVE HOLE VALVE EXTENSION VALVE HOLE BUSHING DIAMETER TYRE BRAKE SHOES</p>	<p>RSF-TRK80 (no labels) RSR-TRK80 (no labels) RS-LAB1 2TK80 (front+rear) - RS-LAB1 2TK80DK (front+rear DARK) 6,5 mm T-19M (male valve extension) - T-19F (female valve extension) RWX-014 (5 pcs) 634 mm See recommended tyre manufacturer inflation pressure for carbon rims - BR-BO500 (for Campagnolo brakes) - BR-BO500X (for Shimano brakes)</p>
---	---	--

SPOKES

<p>FRONT SPOKE REAR RIGHT SPOKE REAR LEFT SPOKE NIPPLES NIPPLE INSERT NIPPLE MAGNET SPOKE SPANNER</p>	<p>RS-01680 RS-01880 RS-01980 RWX-B T-11 T-05 T-18</p>	<p>4 spokes + 4 nipples 4 spokes + 4 nipples 4 spokes + 4 nipples black - 10 pcs magnet-attractor for nipple nipple-guide spoke wrench</p>
---	--	--

ACCESSORIES

<p>Spacer for HG11 FW body</p>	<p>RS-004</p>	<p>5 pcs - to be used only with 9/10s sprockets <i>(please note that every HG11 rear wheel/HG11 FW body package contains the spacer)</i></p>
--------------------------------	---------------	--

⚠ WARNING!

Because of the high temperatures reached when braking, we recommend you use only glue for tubular tires specifically for carbon fibre rims.
A causa delle alte temperature raggiunte in frenata, vi consigliamo di utilizzare solamente colla per tubolari che sia specifica per i soli cerchi in fibra di carbonio.

RACING SPEED™ XLR 80 tubular

HUBS/MOZZI

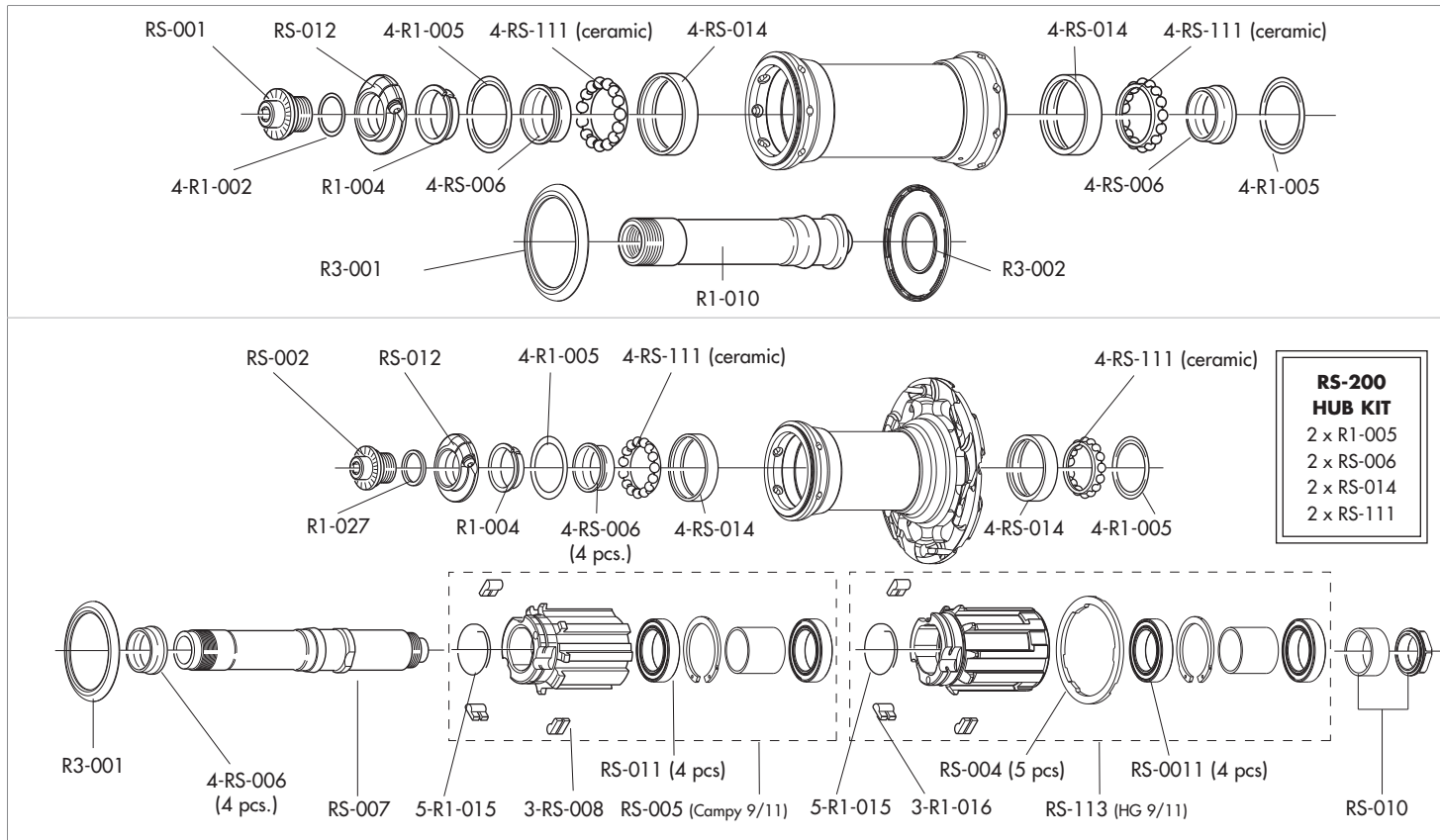

RACING SPEED™ tubular

RIMS & SPOKES/CERCHI E RAGGI

RIM

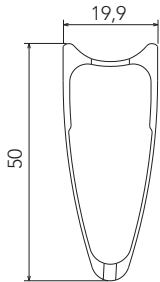
	FRONT RIM REAR RIM LABEL KIT VALVE HOLE VALVE EXTENSION DIAMETER TYRE BRAKE SHOES	RSF-TRK11 (no labels) RSR-TRK11 (no labels) RS-LAB10TAK (front+rear) - RS-LAB12TAKDK (front+rear DARK) 6,5 mm T-08 634 mm See recommended tyre manufacturer inflation pressure for carbon rims - BR-BO500 (for Campagnolo brakes) - BR-BO500X (for Shimano brakes)
--	--	---

SPOKES

COMPLETE FRONT KIT COMPLETE REAR KIT MINI-KIT NUTS NUT SUPPORTING PLATES	RSF-SK02 RSR-SK02 RS-MK02 RS-B RS-C	18 front spokes + 18 nuts + 18 nut supporting plates 14 rear right spokes + 7 rear left spokes + 21 nuts + 21 nut supporting plates 2 front spokes + 2 rear right spokes + 2 rear left spokes + 6 nuts + 6 nut supporting plates 10 pcs 10 pcs
--	---	--

ACCESSORIES

Spacer for HG11 FW body	RS-004	5 pcs - to be used only with 9/10s sprockets <i>(please note that every HG11 rear wheel/HG11 FW body package contains the spacer)</i>
-------------------------	--------	--

WARNING!

Because of the high temperatures reached when braking, we recommend you use only glue for tubular tires specifically for carbon fibre rims.
A causa delle alte temperature raggiunte in frenata, vi consigliamo di utilizzare solamente colla per tubolari che sia specifica per i soli cerchi in fibra di carbonio.

RACING SPEED™ tubular

HUBS/MOZZI

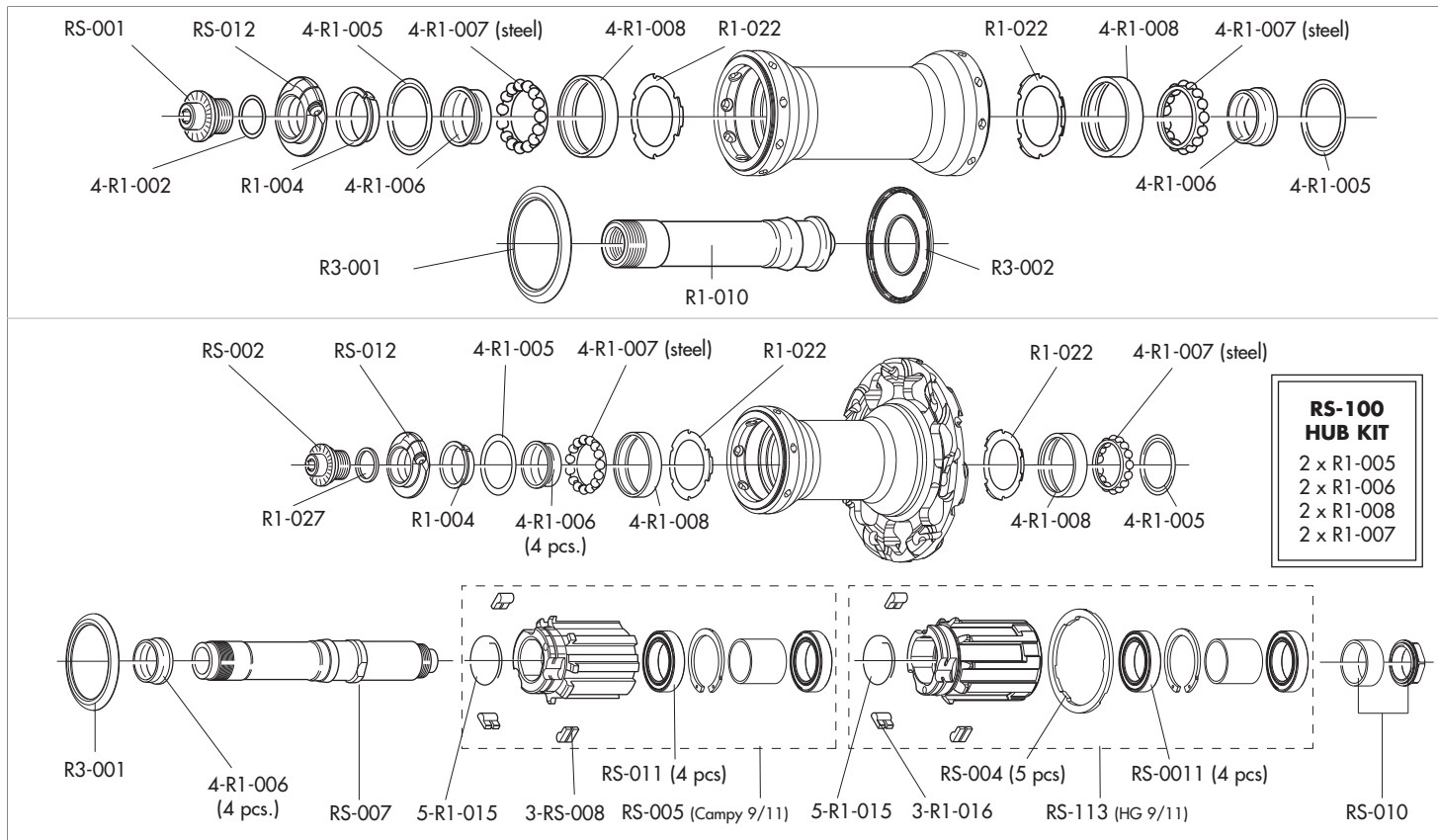

RACING SPEED™ 35 tubular

RIMS & SPOKES/CERCHI E RAGGI

RIM

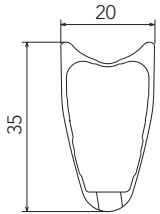
	FRONT RIM REAR RIM LABEL KIT VALVE HOLE DIAMETER TYRE BRAKE SHOES	RSF-TRK3514 (no labels) RSR-TRK3514 (no labels) RS-LAB14TAKDK35 (DARK front+rear) 6,5 mm 634 mm See recommended tyre manufacturer inflation pressure / vedi pressione di gonfiaggio consigliata dal produttore del pneumatico for carbon rims - BR-BO500 (for Campagnolo brakes) - BR-BO500X (for Shimano brakes)
---	---	---

SPOKES

FRONT SPOKE REAR RIGHT SPOKE REAR LEFT SPOKE NIPPLES NIPPLE INSERT NIPPLE MAGNET SPOKE SPANNER SPOKE RING	RS-01635 RS-01835 RS-01935 RWX-B T-11 T-05 T-18 T-02	4 spokes + 4 nipples 4 spokes + 4 nipples 4 spokes + 4 nipples black - 10 pcs magnet-attractor for nipple nipple-guide spoke wrench anti-rotation
--	---	--

ACCESSORIES

Spacer for HG11 FW body	RS-004	5 pcs - to be used only with 9/10s sprockets <i>(please note that every HG11 rear wheel/HG11 FW body package contains the spacer)</i>
-------------------------	--------	--

WARNING!

Because of the high temperatures reached when braking, we recommend you use only glue for tubular tires specifically for carbon fibre rims.
A causa delle alte temperature raggiunte in frenata, vi consigliamo di utilizzare solamente colla per tubolari che sia specifica per i soli cerchi in fibra di carbonio.

RACING SPEED™ 35 tubular

HUBS/MOZZI

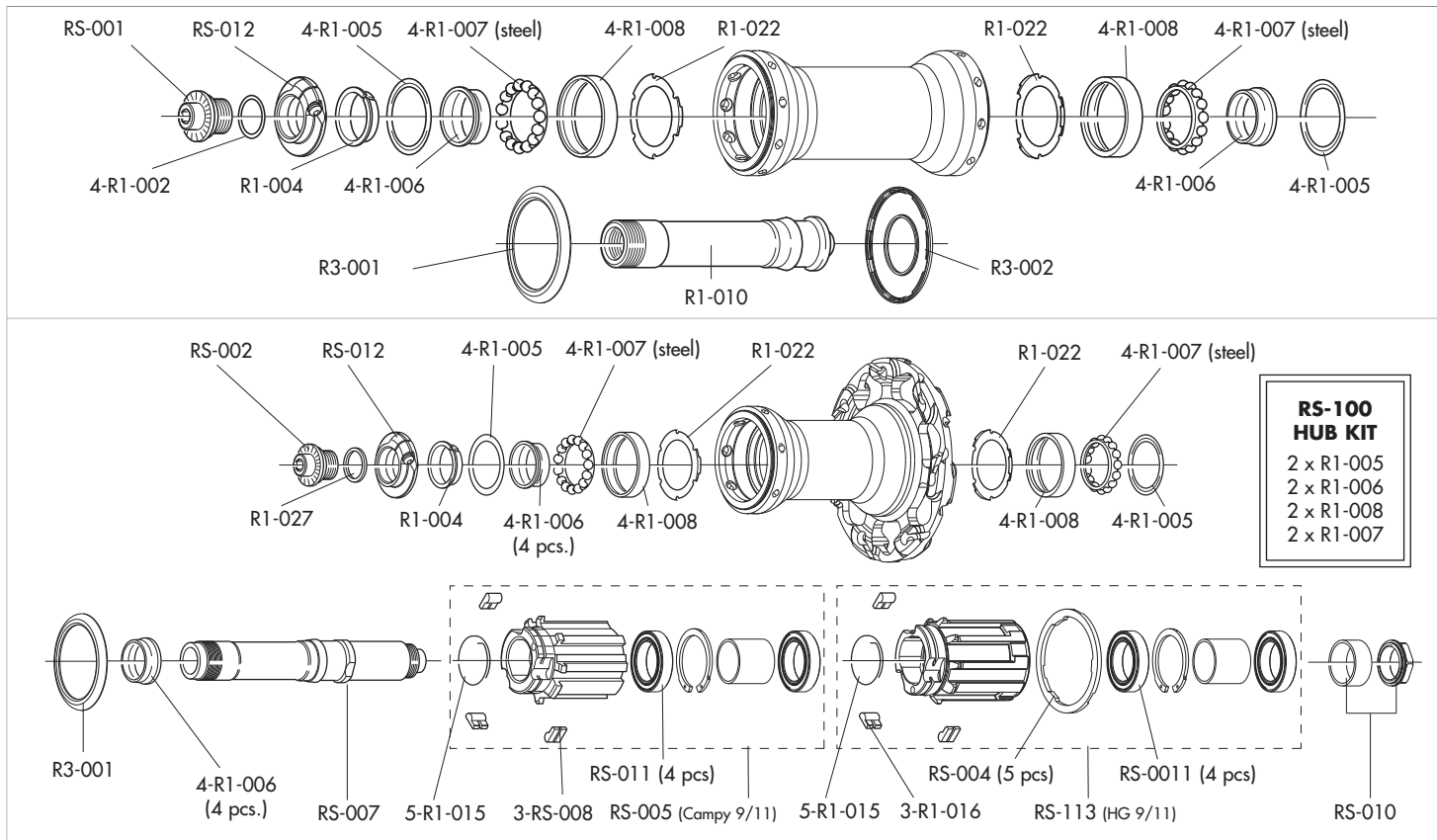

RACING SPEED DISC™ tubular

RIM & HUB / CERCHIO E MOZZO

RIM

WHEEL LABELS	RD-LAB14T
LABEL FOR VALVE HOLE	RC-100 (5 pcs)
TYRE	See recommended tyre manufacturer inflation pressure

HUB

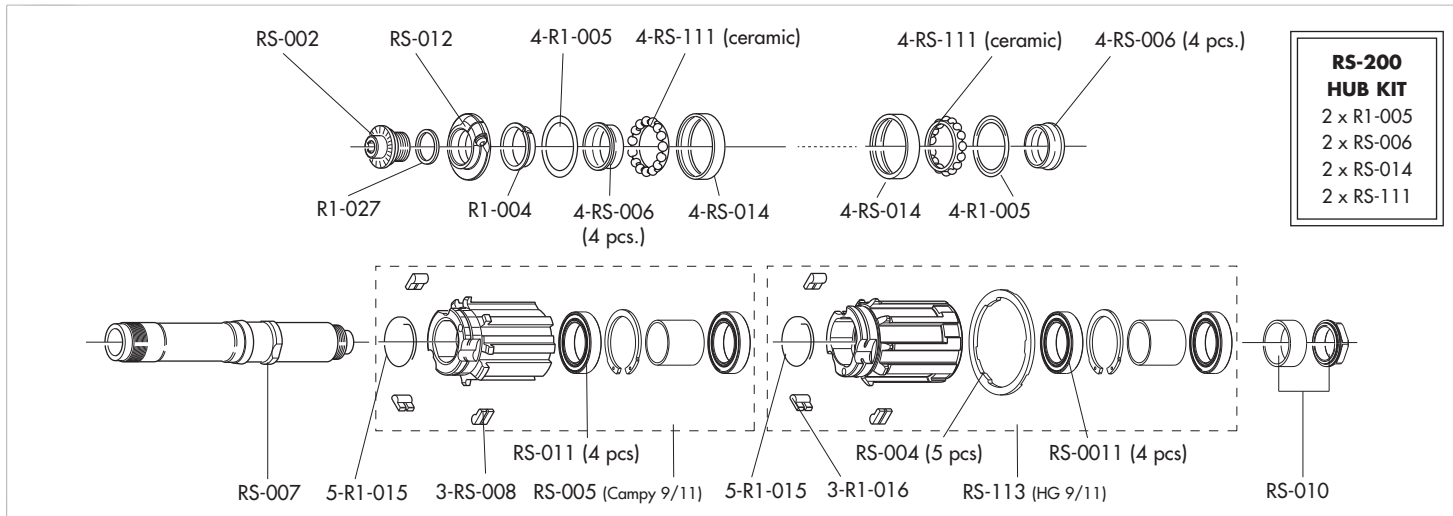

QUICK RELEASE



2-Way Fit™ WHEELS

RACING ZERO

R1-QFR

RACING 1

R1-QFR

RACING 3

R1-QFR

CLINCHER/TUBULAR WHEELS

RACING ZERO

R1-QFR

RACING 1

R1-QFR

RACING 3

R3-QFR12

RACING QUATTRO

R3-QFR12

RACING 5

R5-QFR02

RACING 7

R5-QFR02

RACING SPORT

R5-QFR02

RACING SPEED DISC™

RWX-QFR12

ALU/CARBON WHEELS

RED WIND™ XLR

RWX-QFR12

RED WIND™ XLR 80 mm

RWX-QFR12

RED WIND™ XLR 105 mm

RWX-QFR12

RED WIND™

R3-QFR12

RED WIND™ 80 mm

R3-QFR12

CARBON WHEELS

RACING LIGHT™ XLR

RWX-QFR12

RACING SPEED™ XLR

RWX-QFR12

RACING SPEED™

RWX-QFR12

RACING TORQ™ RRS

CARBON CRANKSET

B	170 mm	CC-RRS451
	172,5 mm	CC-RRS453
	175 mm	CC-RRS455
C	Z39	CC-RRS039
D	Z52 for 39	CC-RRS052
	Z53 for 39	CC-RRS053

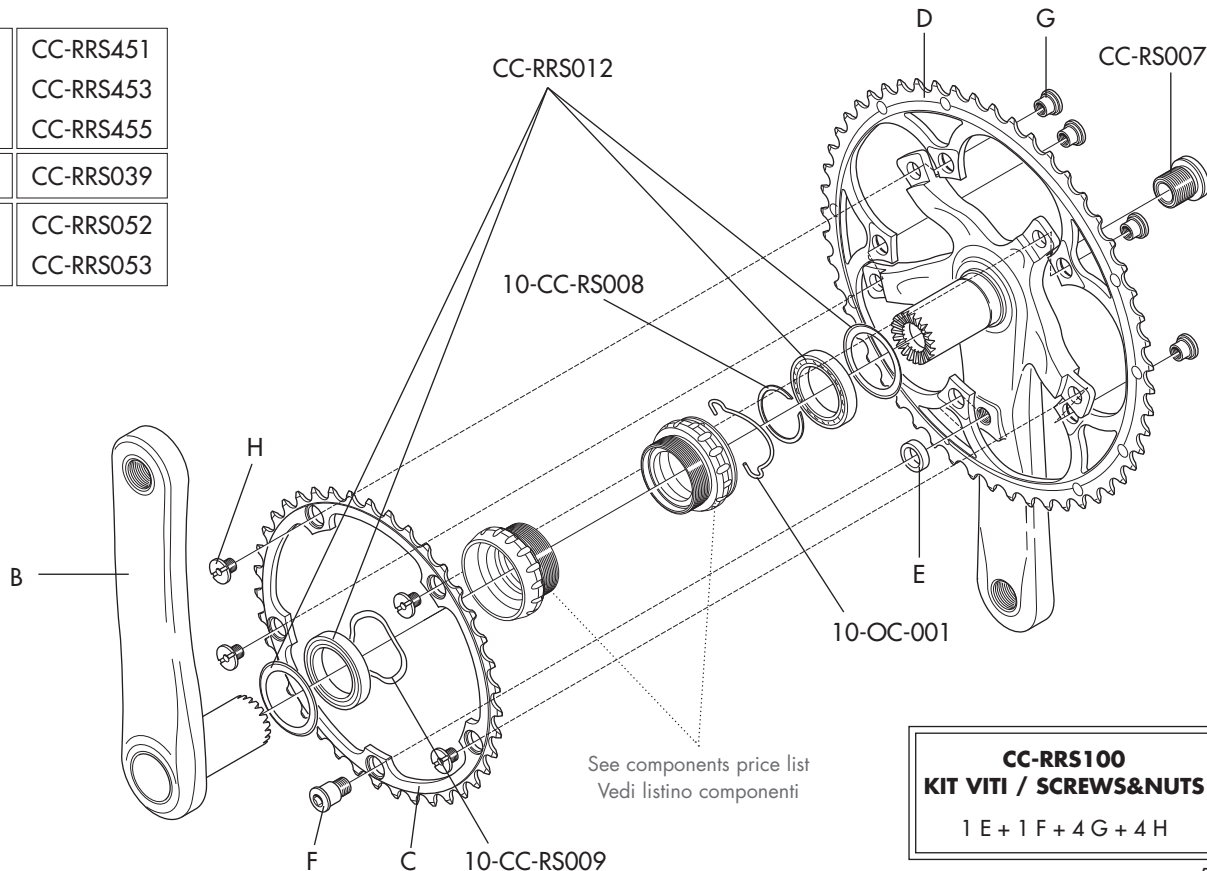

CC-RRS100
KIT VITI / SCREWS&NUTS
 1 E + 1 F + 4 G + 4 H

RACING TORQ™ RRS CT

CARBON CRANKSET

B	170 mm	CC-RRS451
	172,5 mm	CC-RRS453
	175 mm	CC-RRS455
C	Z34	CC-RRS034
D	Z50 for 34	CC-RRS050

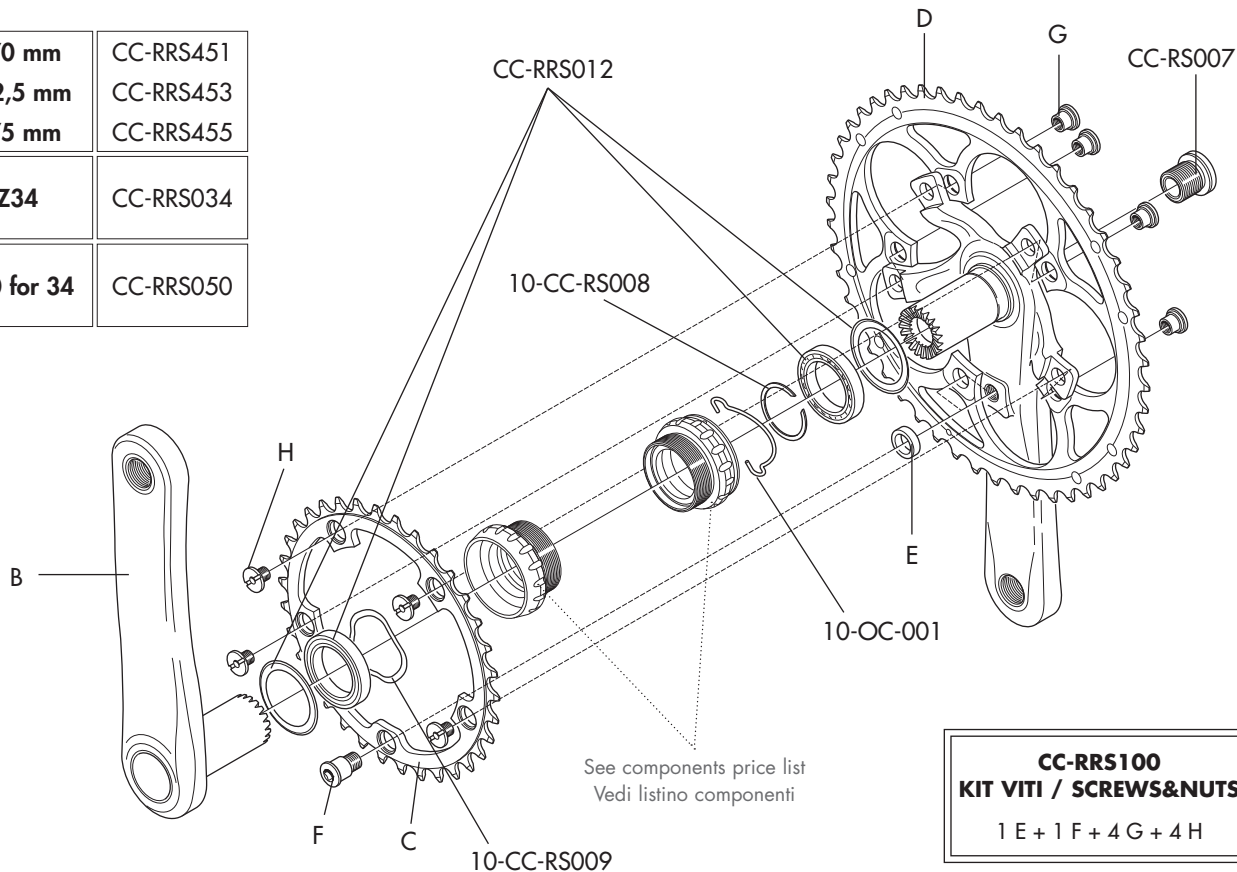

RACING TORQ™ R

CARBON CRANKSET

B	170 mm	CC-R421
	172,5 mm	CC-R423
	175 mm	CC-R425
C	Z39	CC-R039
D	Z52 for 39	CC-R052
	Z53 for 39	CC-R053

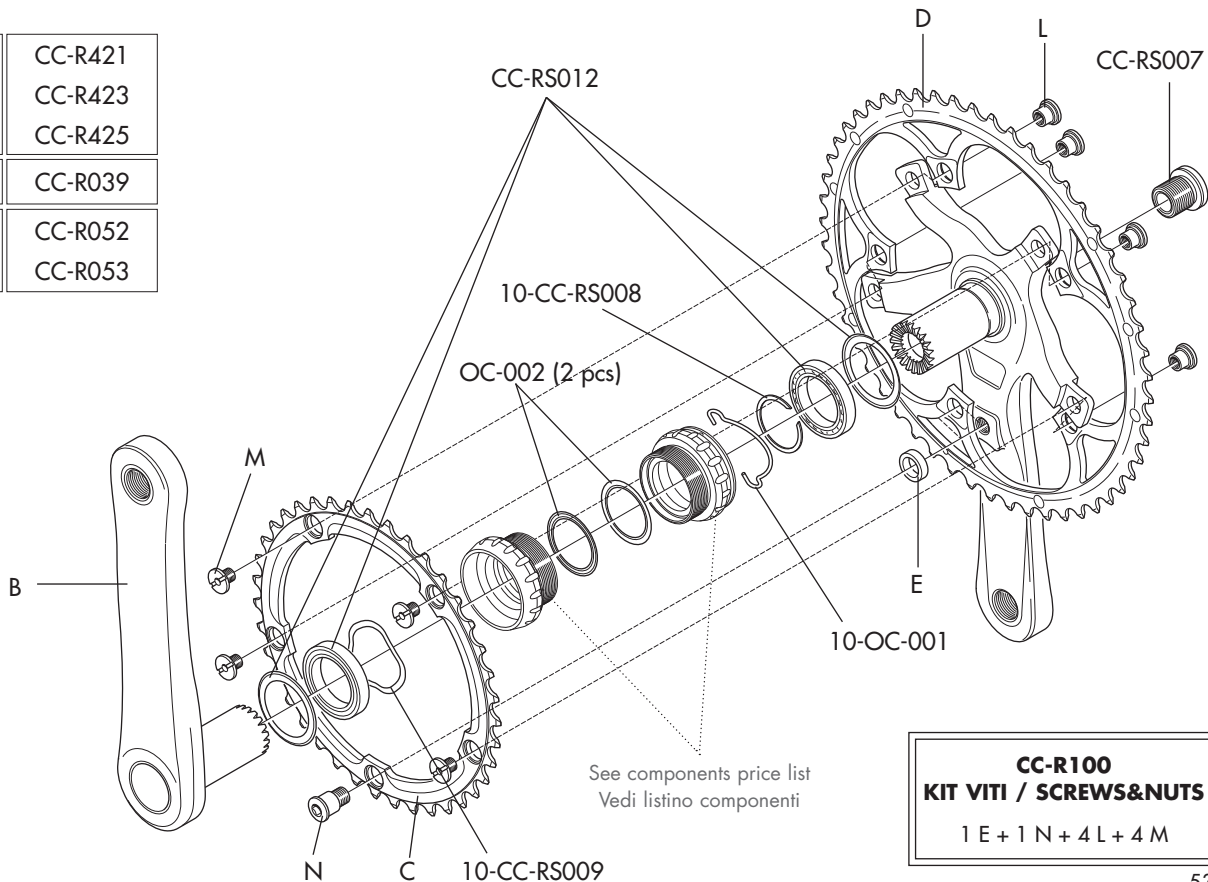

CC-R100
KIT VITI / SCREWS&NUTS
1 E + 1 N + 4 L + 4 M

RACING TORQ™ R CT

CARBON CRANKSET

B	170 mm	CC-R421
	172,5 mm	CC-R423
	175 mm	CC-R425
C	Z34	CC-R034
D	Z50 for 34	CC-R050

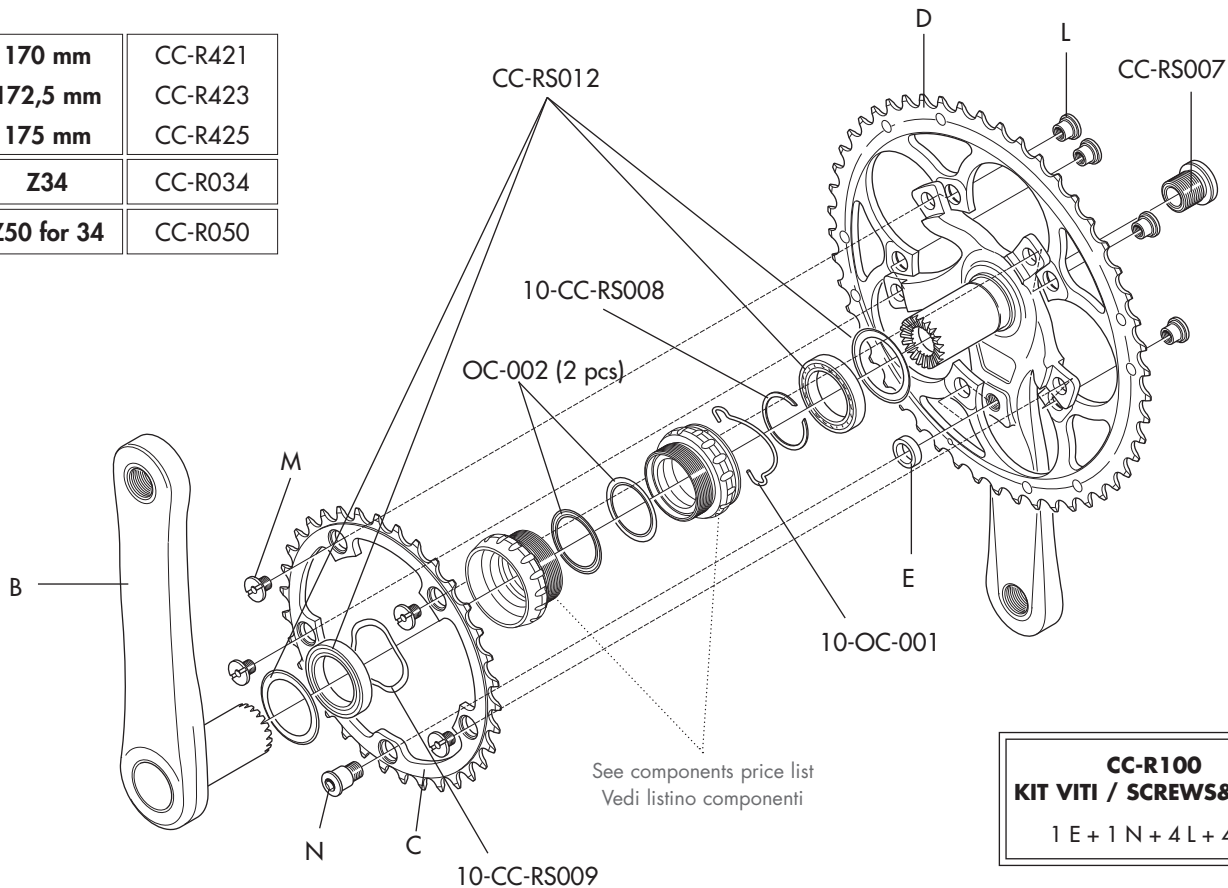

RED WIND™ XLR CX CLINCHER

RIMS & SPOKES/CERCHI E RAGGI

RIM

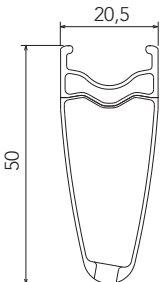
	<p>FRONT RIM REAR RIM LABEL KIT VALVE HOLE VALVE EXTENSION DIAMETER TYRE</p>	<p>RWXF-CR (no labels) RWXR-CR (no labels) RWX-LAB13 (front+rear) - RWX-LAB13DK (front+rear DARK) 6,5 mm T-15M (male valve extension) - T-15F (female valve extension) 700C (622 x 15C) See section table and inflation pressures on page 66</p>
---	--	--

SPOKES

<p>COMPLETE FRONT KIT COMPLETE REAR KIT MINI-KIT NIPPLES SPOKE RING NIPPLE INSERT NIPPLE MAGNET SPOKE SPANNER</p>	<p>RWXF-SK RWXR-SK RWX-MK RWX-B T-02 T-11 T-05 T-18</p>	<p>18 front spokes + 18 nuts + 18 nut supporting plates 14 rear right spokes + 7 rear left spokes + 21 nuts + 21 nut supporting plates 2 front spokes + 2 rear right spokes + 2 rear left spokes + 6 nuts + 6 nut supp. plates black - 10 pcs anti-rotation magnet-attractor for nipple nipple-guide spoke wrench</p>
--	--	--

RED WIND™ XLR CX CLINCHER

HUBS/MOZZI

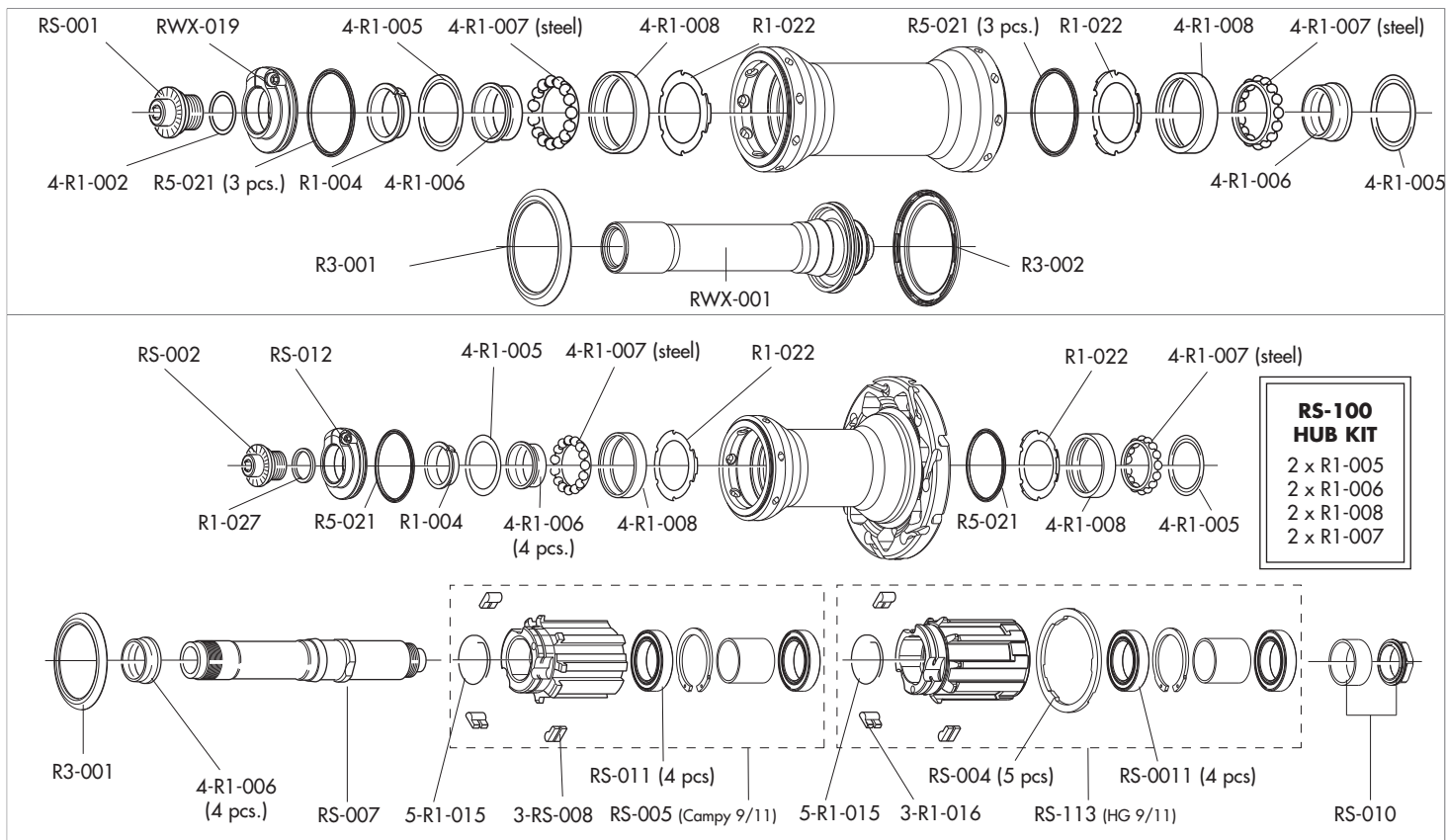

RACING QUATTRO CX CLINCHER

RIMS & SPOKES/CERCHI E RAGGI

RIM

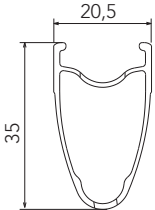
	LABEL KIT VALVE HOLE DIAMETER TYRE SECTION	R4-LAB13CXB (front+rear) 6,5 mm 622 X 15C See section table and inflation pressures on page 66
---	---	---

SPOKES

FRONT SPOKE REAR RIGHT SPOKE REAR LEFT SPOKE NIPPLES	R4-016 R4-018 R4-019	4 pcs 4 pcs 4 pcs 50 pcs
---	----------------------------	-----------------------------------

RACING QUATTRO CX CLINCHER

HUBS/MOZZI/MOYEUX

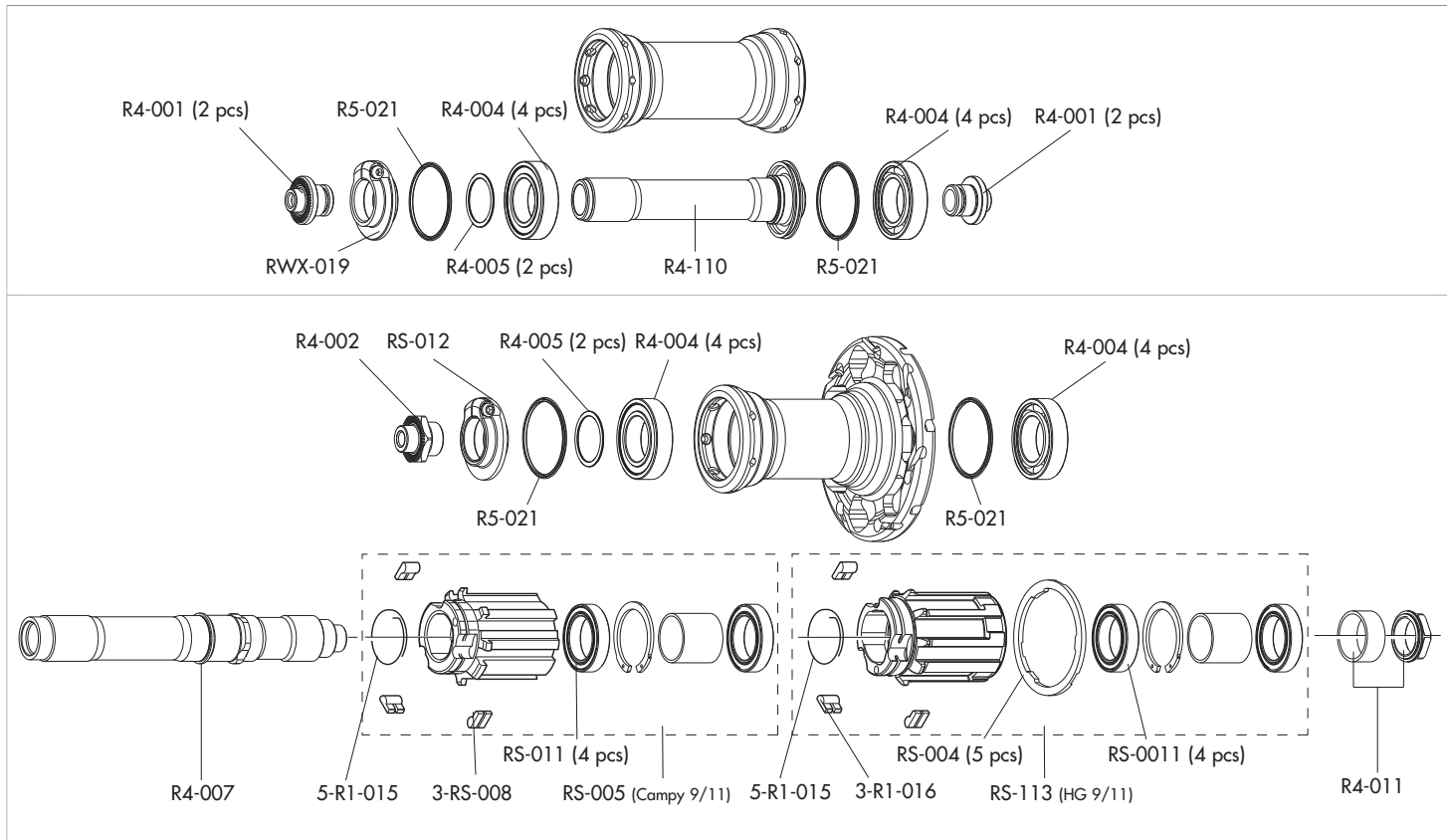

RACING 5™ CX CLINCHER

RIMS & SPOKES/CERCHI E RAGGI

RIM

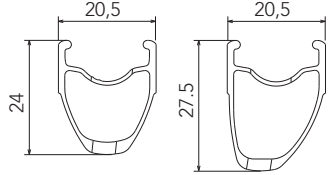
	<p>RIM-TAPE LABEL KIT VALVE HOLE DIAMETER TYRE SECTION</p>	<p>2-RL-RT (18 mm - 2 pcs) R5-LAB14CXB (front+rear) 6,5 mm 622 X 15C See section table and inflation pressures on page 66</p> <p>* These wheels are designed to mount cyclo-cross up to 35 mm tyres. We highly recommend complying with maximum pressures indicated on cyclo-cross tyres. Do not use 29" MTB tyres.</p>
--	--	---

SPOKES

<p>FRONT SPOKE REAR RIGHT SPOKE REAR LEFT SPOKE NIPPLES</p>	<p>R5-216 R5-218 R5-119 R5-B</p>	<p>4 pcs 4 pcs 4 pcs 50 pcs</p>
---	--	---

ACCESSORIES

<p>Spacer for HG11 FW body</p>	<p>RS-004</p>	<p>5 pcs - to be used only with 9/10s sprockets <i>(please note that every HG11 rear wheel/HG11 FW body package contains the spacer)</i></p>
--------------------------------	---------------	--

RACING 5™ CX CLINCHER

HUBS/MOZZI/MOYEUX

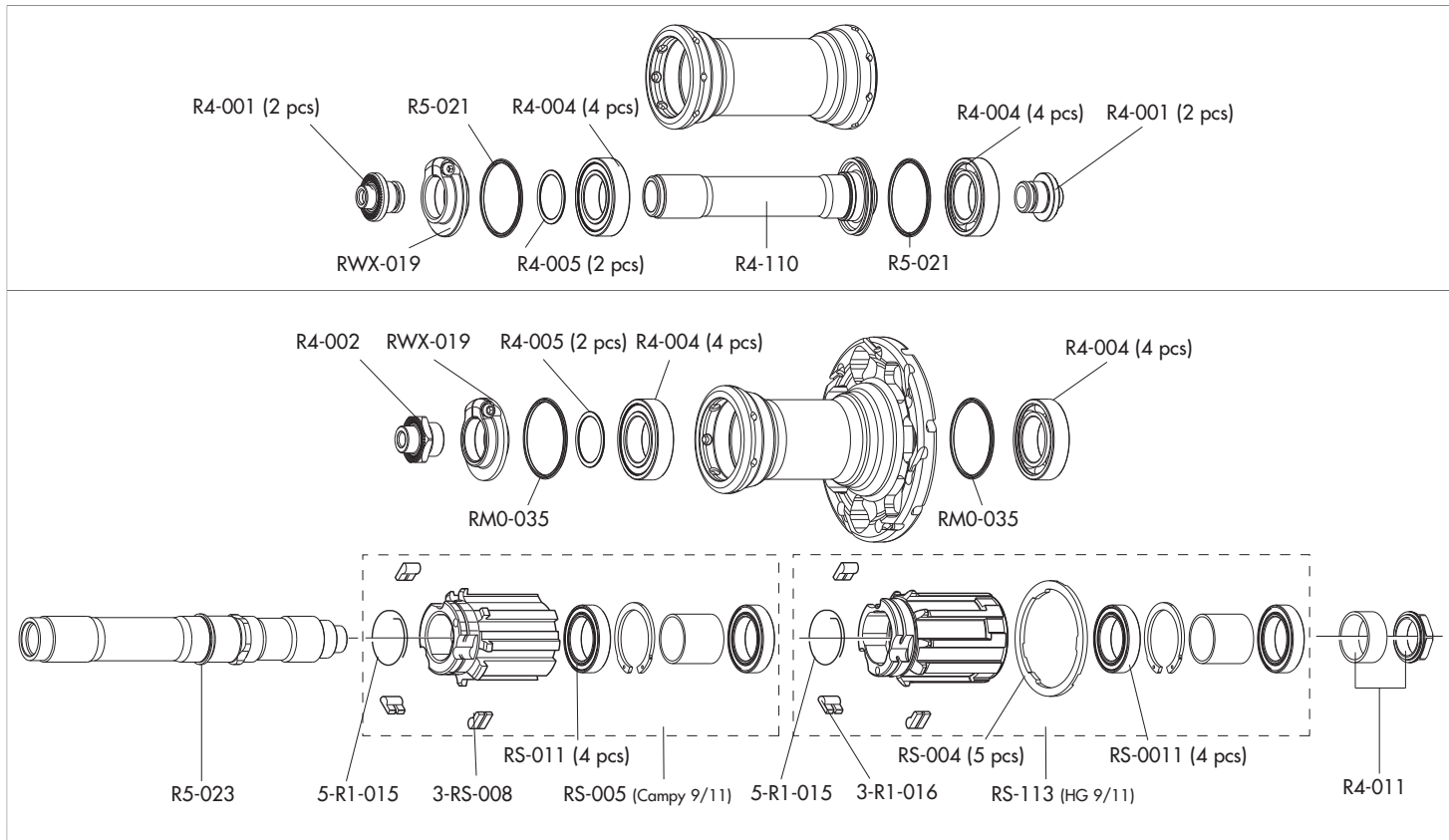

RACING 7™ CX CLINCHER

RIMS & SPOKES/CERCHI E RAGGI

RIM

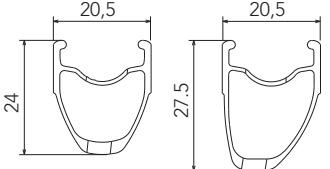
	RIM-TAPE LABEL KIT VALVE HOLE DIAMETER TYRE SECTION	2-RL-RT (18 mm - 2 pcs) R7-LAB14CXB (front+rear) 6,5 mm 622 X 15C See section table and inflation pressures on page 66
--	---	--

SPOKES

FRONT SPOKE REAR RIGHT SPOKE REAR LEFT SPOKE	R7-116 R7-018 R7-019	4 pcs 4 pcs 4 pcs
--	----------------------------	-------------------------

ACCESSORIES

Spacer for HG11 FW body	RS-004	5 pcs - to be used only with 9/10s sprockets <i>(please note that every HG11 rear wheel/HG11 FW body package contains the spacer)</i>
-------------------------	--------	--

RACING 7™ CX CLINCHER

HUBS/MOZZI

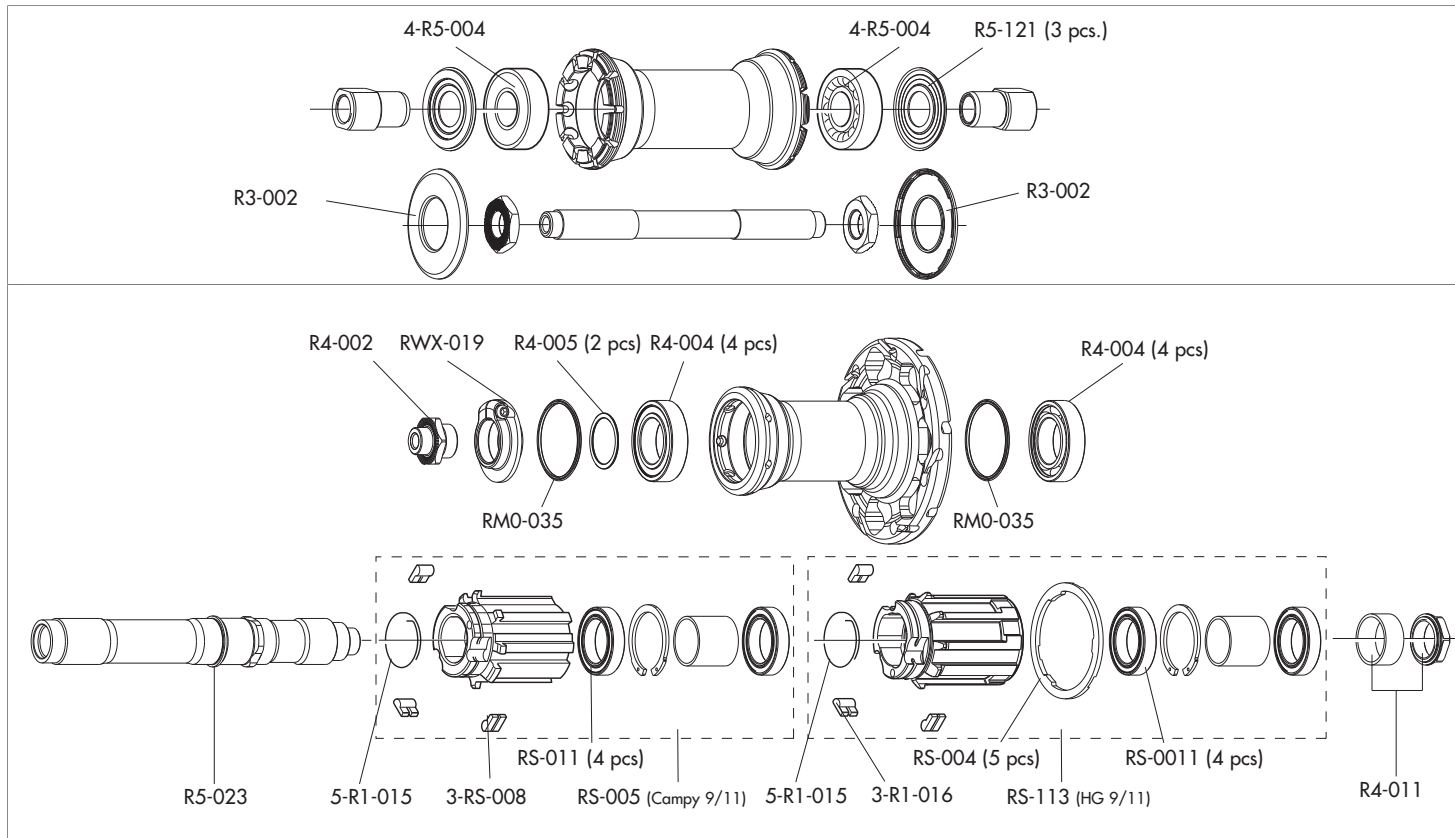



MAXIMUM OPERATING PRESSURE

			RIM WIDTH			
			13C		15C	
			mm	in.	BAR	PSI
TYRE WIDTH	18	0,70	10,0	146		
	20	0,80	9,5	138		
	23	0,90	9,5	138	9,5	138
	25	1,00	9,0	131	9,0	131
	28	1,10			8,0	117
	30	1,20			7,0	103
	32	1,25			6,7	99
	35	1,30			6,3	93

VALVE EXTENSIONS

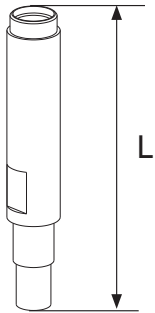
NOTE:
USE AIR CHAMBERS
(INNER TUBES) WITH
A LONG VALVE (AT
LEAST 35 mm).

PROFILE RIM	MALE VALVE ADAPTER (SUPPLIED)		
RED WIND/RED WIND XLR H50	T-15M	L = 35 mm	
RED WIND/RED WIND XLR H80	T-16M	L = 65 mm	
RED WIND/RED WIND XLR H105	T-17M	L = 90 mm	
RACING SPEED XLR H80	T-19M	L = 74 mm	
PROFILE RIM	FEMALE VALVE ADAPTER (OPTION)		
RED WIND/RED WIND XLR H50	T-15F	L = 37 mm	
RED WIND/RED WIND XLR H80	T-16F	L = 67 mm	
RED WIND/RED WIND XLR H105	T-17F	L = 92 mm	
RACING SPEED XLR H80	T-19F	L = 80 mm	